

Assessment of High Concentrated Photovoltaic/Thermal Collector in Hot Climate

Kandil M. Kandil^{1*}, Talal H. Alzanki², Ibrahim M. Kadad¹

¹Applied Sciences Department, College of Technological Studies, Public Authority for Applied Education and Training (PAAET), Shuwaikh, Kuwait

²Electronic Engineering Department, College of Technological Studies, Public Authority for Applied Education and Training (PAAET), Shuwaikh, Kuwait

Email: *km.kandil@paaet.edu.kw

How to cite this paper: Kandil, K.M., Alzanki, T.H. and Kadad, I.M. (2019) Assessment of High Concentrated Photovoltaic/Thermal Collector in Hot Climate. *Smart Grid and Renewable Energy*, 10, 119-140. <https://doi.org/10.4236/sgre.2019.105008>

Received: March 28, 2019

Accepted: May 14, 2019

Published: May 17, 2019

Copyright © 2019 by author(s) and Scientific Research Publishing Inc. This work is licensed under the Creative Commons Attribution International License (CC BY 4.0). <http://creativecommons.org/licenses/by/4.0/>



Open Access

Abstract

This work investigates the performance of combined hybrid high concentrated photovoltaic/thermal collector (HCPV/T) in Kuwait harsh climate. The proposed system consists of triple junction solar cells (InGaP/InGaAs/Ge) attached to heat source to discharge thermal energy to cooling media. Published HCPV/T models do not consider the effect of shunt resistance which greatly affects the system performance. So, a single diode model employing five parameters including the effect of shunt resistance is adapted to analyze the proposed system. To analyze the thermal performance of the proposed system, a two-dimensional thermal model based on the technique of finite difference is introduced to determine the efficiency of the hybrid HCPV/T system. The present developed subroutines are integrated with other involved codes in TRNSYS software to calculate HCPV/T system efficiency. Electrical and thermal as well as the whole system efficiency at different weather circumstances are evaluated and assessed. The effect of different weather conditions, cell temperature, concentration ratio and the temperatures of the coolant fluid on system performance are studied. Current results indicate that the model of single diode is a reliable one rather than using the two-diode complex model. Compared to measurements provided by high concentrated PV manufacturer, the current results revealed a total root mean square error of approximately 1.94%. Present predictions show that PV cell temperature has logarithmic increase with the rise in concentration ratio but with low values till concentration ratio of 400 suns after that the rise is faster at higher concentration values up to 1500 suns. Results also revealed that hybrid HCPV/T system works effectively specially in severe hot climate where thermal efficiency increases with high surrounding temperature for higher values of concentration ratio. In addition, an increase of approximately 15% in thermal ef-

efficiency and 10% in total efficiency can be achieved by utilizing active cooling device in HCPV/T system.

Keywords

Multijunction PV Cells, High Concentrated Solar Cells, Thermal Collector, Electrical Efficiency, Thermal Efficiency

1. Introduction

As a result of growing demand to electricity generation due to population increase in addition to the awareness of pollution problems, solar cell research and technology has significantly improved in recent years. On the other hand, different solar thermal system types are utilized on large scale to supply thermal energy in different applications as water heating, air conditioning and water desalination. Solar cells have attained electrical efficiency of 46% [1], however, recorded efficiencies of marketed PV modules are much lower than that value. An important fact is that most of solar energy lost as heat in PV system can be utilized by integrating with thermal systems. Several researchers paid a great attention to hybrid PV/thermal (PVT) system. In that system, solar energy can be employed to generate both thermal and electrical energy [2] [3]. In addition, hybrid PV/thermal collector decreases the expenses of installation and can be admitted to various applications requiring electrical and thermal energy [4].

Combined system linking high concentrating PV cells is considered as one of the most successful methods used to trap both heat and electricity at the same time. High concentrated photovoltaic and thermal system (HCPV/T) links three techniques, mainly optical system, triple-junction PV cell and the heat sink, to discharge heat generated from triple-junction solar cell. In this situation, it is very important to study the effect of different system parameters as PV cell temperature, ambient temperature, temperature of the cooling fluid and concentration ratio on the efficiency of such system. The HCPV/T system is comprised of multijunction PV solar cell with significantly high efficiency [5] [6]. The triple junction InGaP/InGaAs/Ge is proposed for the current work as it possesses the highest performance in addition to its relative cost compared to other available multijunction solar cells [7] [8]. So, the above-mentioned hybrid system has three objectives: achieving high energy needs for different applications, minimizing global warming as well as minimizing the expenses of produced energy [9]. High concentrated PV cells employ Fresnel lens to concentrate solar radiation on a tiny area of solar cell. So, HCPV area in the center of the concentration is decreased by the value of concentration ratio. This allows the use of expensive but highly efficient triple-junction solar cells. A 30 kW concentrator PV system employing Fresnel lenses having dome-shaped is introduced by Araki *et al.* [10]. Xie *et al.* [11] presented a revision of the utilization of Fresnel lenses in the last years.

When the concentration ratio of HCPV/T modules increases, this leads to an increase in cell temperature resulting in a decrease in cell performance in addition to performance degradation because of the long exposure of the cell to high temperature which decreases the time life of PV cell. In that regard, the temperature of HCPV cell is the most significant factor affecting cell efficiency. It is claimed by Skoplaki and Palyvos [12] that the average decrease in the efficiency of the cell is 0.45% for each one degree rise in cell temperature. Nishioka *et al.* [13] revealed that the most important factor affecting cell performance as well life time of HCPV cell is the cell working temperature. They indicated that for triple junction solar cell, electrical efficiency decreases at 1 sun by approximately 0.25% while it decreases by 0.098% at 200 suns for each 1 degree increase in cell temperature.

A secondary refractive or reflective element is commonly utilized after the Fresnel lens to increase the optical strength to the angle of acceptance as well as improving the homogeneity of solar radiation throughout HCPV cell. This component will increase the solar concentration through high concentrated PV/thermal modules. The HCPV/T hybrid system is desired to enhance high concentrating solar cell more as it transfers solar radiation to both thermal energy and electrical energy. The passive or active cooling technique that disposes heat from the HCPV cell is the most significant parameter that should be taken into consideration when manufacturing HCPV/T system. An extensive analysis has been presented by Royne *et al.* [14] for different cooling methods employed in HCPV/thermal systems. They concluded that passive cooling for linear concentrator is not suitable for concentration ratio higher than 20 suns.

Optical concentrators increase the solar radiation incident on cell area and HCPV power can be greatly enhanced by utilizing adequate concentration ratio [15]. III-V multi-junction solar cells can be employed to obtain higher efficiencies. Also, the thermal receiver area greatly decreases leading to significant reduction in the thermal losses. So, the thermal system will have a higher thermal efficiency than the regular flat-plate/thermal system. Jakhar *et al.* [16] discussed in detail the different active and passive cooling techniques employed in HCPV/T systems. They revealed that the cooling design of HCPV/T system greatly depends area solar radiation beside the concentration ratio. So, it is advice to utilize passive cooling for low and medium concentration ratios, because the expense is twice compared to the case for high concentration ratio. On the other hand, it is better to utilize active cooling in the case of higher concentration ratio. The dependence of the parameters of triple junction solar cell and both cell temperature and concentration ratio are analyzed by Ben and Appelboun [17]. They illustrated that raising concentration ratio leads to an increase in the photocurrent, junction saturation current and ideality factor of junction while it results in a decrease in both shunt resistance and series resistance. While as solar cell temperature increases, the photocurrent and series resistance increase while ideality factor and the shunt resistance decrease.

Xu *et al.* [18] studied the relation between HCPV/T module performance and both temperature and radiation levels adapting Fresnel lens. The outcomes indicated that solar radiation has a significant impact on electrical efficiency while mass flow rate of cooling water, cell temperature and solar radiation increases thermal efficiency. Also, thermal efficiency decreases with increasing water temperature and wind speed. It is important to mention that Xu *et al.* did not consider the shunt resistance in their work which is very vital for multijunction solar cells losses. Study of the current situation of HCPV/T market [19] show that there is still a lack of information concerning the properties and manufacture of HCPV modules. In addition, most available knowledge on HCPV/T systems are not complete and consequently still need more extensive analysis [20].

The above mentioned discussions reveals that the performance of hybrid HCPV/T is not studied in hot climate, in addition there is no enough knowledge about the cooling techniques used in this system. The present study introduces a numerical model developed to evaluate the HCPV/T system performance considering these factors. Single diode model with the five parameters method is utilized to determine the electrical efficiency of HCPV/T system. To analyze the thermal and total performance of hybrid HCPV/T system, a thermal model based on two-dimensional finite difference technique is developed. Introduced codes are compatible with other build in subroutines in TRANSYS software [21]. These subroutines are integrated with other TRNSYS subroutines as weather data generator to analyze the performance of HCPV/T system. Using present developed numerical models, thermal, electrical as well as total system efficiency can be calculated at various running parameters. Furthermore, cell temperature as function of concentration ratio at different radiation, ambient temperature and cooling water temperature are evaluated by running TRNSYS simulation using climate conditions of Kuwait. It is hoped that present work will furnish more awareness and marketing of this high effective technology.

2. Numerical Models

2.1. HCPV/T System Design

HCPV/T system structure using Fresnel lens optics is composed of first Fresnel lens to refract solar radiation, second radiation is refracted by optical prism to be focused on the surface of the cell. HCPV is embedded on heat sink to discharge thermal heat to the coolant fluid. So, there is an adequate surface on the heat sink for thermal energy dissipation from the small area of HCPV. In this situation, solar cell always operates at regular temperature and solar cell performance will not degrade.

2.2. Thermal Model

The hybrid HCPV/T system suggested is presented in **Figure 1**. The system comprises a thermal system to absorb thermal energy from the cold water passes in a circular shape pipe. The pipe is positioned in good thermal contact to

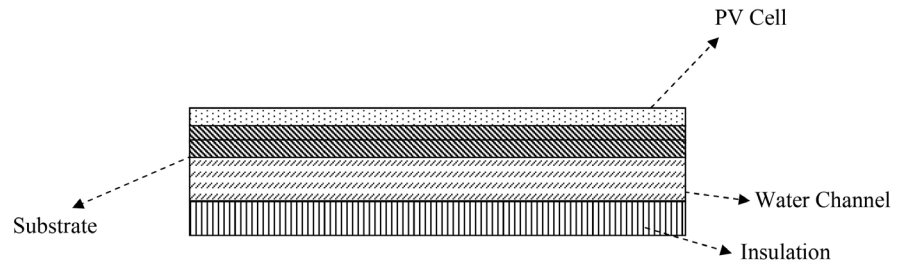

Figure 1. Schematic of Hybrid HCPV/T System

Figure 1. Schematic of hybrid HCPV/T system.

HCPV solar cells, allowing both production of heat and cooling of the cell. Receiver bottom surface which faces the concentrator is provided with triple-junction cells InGaP/InGaAs/Ge while other surfaces are maintained insulated. Solar radiation incident on HCPV surface ensures the heating of selective layer fixed below the cells to improve heat transfer by convection and conduction between the fluid and the metal channel.

Heat is transferred from HCPV/T system to surrounding by two different techniques. The first method is heat transfer by convection from cell layer to the surrounding. The second technique is heat losses by radiation from cell outside surface to the surrounding sky. Simplified models for calculation of the performance of HCPV/T published in the literature cannot be used with current proposed hybrid system as using multijunction solar cells and concentrating technique. An accurate numerical model employing finite difference method is developed for current study by applying energy balance equation for each element. The two-dimensional analysis utilizes finite difference technique utilizing FORTRAN code to formulate different equations. To simplify numerical analysis, different approximations are taken into consideration. Collector surface and receiver dimensions are fixed. In addition, elements physical properties are kept constants. Solar radiation at the absorber is assumed to be homogeneously distributed as well as the uniformity of ambient temperature around the solar collector.

Heat collected on PV surface transmitted from heat sink surface very fast. Fraction of the heat is gathered by inlet water (Q_{th}) and remaining part is (Q_{loss}) is lost by radiation and convection to the ambient. A finite difference method is adapted to solve the equations. One can get the finite difference equation by applying energy balance equation for every node utilizing energy conservation principle to each control volume in the region of the specified node. A steady state two-dimensional heat transfer model using energy balance technique is proposed. Heat dissipated by convection to water is Q_{th} and Q_{loss} is heat transferred to ambient by radiation and convection. This decreases the thermal model to a plate with two-dimensional model at different boundary conditions. Finite difference equations are solved to obtain the thermal profile. In each domain, there are three different regions, the heat sink region, the cell region and the water region. To precisely develop energy balance equations, the domain is divided

into different small areas.

Applying the first law of thermodynamics, the general balance of energy for the HCPV/T system is:

$$Q_{abs} = Q_{el} + Q_{th} + Q_{opt} + Q_{loss} \quad (1)$$

where Q_{abs} is the solar energy collected by PV cell surface (as defined in Equation (3)), Q_{el} is the photovoltaic output by the array, Q_{th} is heat gained by the circulating water, Q_{opt} is the optical losses in primary and secondary optical components and Q_{loss} is the heat lost to the surroundings by radiation and convection. The optical losses Q_{opt} is given as:

$$Q_{opt} = Q_{abs} (1 - \eta_{opt}) \quad (2)$$

The thermal energy (Q_{th}) absorbed by circulating water is expressed as:

$$Q_{th} = \dot{m} c_p (T_o - T_i) \quad (3)$$

where c_p is water specific heat, \dot{m} is the mass flow rate, T_i is the circulating water inlet temperature, T_o is circulating water outlet temperature,

Thermal energy is lost to surroundings by radiation (Q_{rad}) as well as convection (Q_{conv}). So:

$$Q_{loss} = Q_{rad} + Q_{conv} \quad (4)$$

The coefficient of radiative heat transfer (h_{rad}) to ambient is usually expressed in the form (Duffie and Backman 2013):

$$h_{rad} = \varepsilon_v \sigma (T_{sky}^2 + T_f^2) (T_{sky} + T_f)$$

where σ is Stefan-Boltzmann constant ($5.7 \times 10^{-8} \text{ W/m}^2\text{K}^4$); ε is emissivity of the surface; T_f is the mean temperature of the fluid; T_{sky} is the external sky temperature which is needed to calculate radiative exchange and its change correlated to ambient temperature (T_{amb}) in the form [22]:

$$T_{sky} = 0.0552 T_{amb}^{1.5} \quad (5)$$

The coefficient of convective heat transfer (h_{conv}) from outside surface which is in contact with the ambient is usually expressed related to wind velocity (v_w) in the form [23]:

$$h_{conv} = 2.8 + 3v_w \quad (6)$$

Water convective heat transfer coefficient (h_w) is related to characteristics of flow according to (Incropera *et al.* 2007):

$$h_w = \frac{Nu k}{D} \quad (7)$$

where Nu is Nusselt number, D is tube diameter and k is thermal conductivity. Nusselt number is given by:

$$Nu = 4.36 \quad \text{for } Re < 2300 \quad (8)$$

$$Nu = 0.023 Re^{0.8} Pr^{1/3} \quad \text{for } Re > 2300 \quad (9)$$

where Pr is Prandtl number and Re is Reynolds number.

Portion of radiation is absorbed by solar cell to produce electricity while the remain part is converted to heat (q_{th}) as:

$$Q_{th} = Q_{abs} (1 - \eta_{el}) \quad (10)$$

where q_{abs} is solar radiation flux on PV area (W/m^2) and η_{el} is PV electrical efficiency expressed in terms of thermal coefficient (β_{th}), average PV temperature (T_{PV}), reference temperature (T_{ref}) and efficiency at reference temperature (η_{Tref}) expressed as:

$$\eta_{el} = \eta_{Tref} - [\beta_{th} (T_{PV} - T_{ref})] \quad (11)$$

Heat is transferred by conduction in the layers of multijunction solar cell while some heat is lost to surrounding by natural and forced convection. In addition, fraction of thermal energy is removed by radiation to the environment from the assembly surfaces. Heat pipe is usually enclosed by a vacuum in evacuated tube collector. This technique minimizes the heat dissipated by convection and conduction.

The photovoltaic efficiency of the HCPV/T array to transfer solar radiation to electrical energy is obtained by:

$$\eta_{el} = \frac{Q_{el}}{A_{ap} G} \quad (12)$$

The instantaneous hybrid HCPV/T thermal efficiency is:

$$\eta_{th} = \frac{Q_{th}}{A_{ap} G} = \frac{\dot{m} c_p (T_o - T_i)}{A_{ap} G} \quad (13)$$

The hybrid HCPV/T system total efficiency (η_t) is determined from thermodynamics first-law. So, HCPV/T total efficiency (η_t) can be considered as the addition of both electrical and thermal efficiency [24] [25]:

$$\eta_t = \eta_{el} + \eta_{th} \quad (14)$$

The total efficiency of HCPV/T system can be determined from first-law of thermodynamics, however, it neglects the difference between electrical output generated by a module and thermal energy. A temperature difference should exist between high temperature heat source and a low temperature one. At the same time, electrical energy can totally transfer to work. So, the energetics efficiency (second-law efficiency) results in more precise values of total performance of HCPV/T system. Exergy is the accessible energy attained by subtracting the unavailable energy from overall energy and is equal to the work converted. So, in current work the second-law of thermodynamic is employed to calculate HCPV/T system total efficiency. The equation used by Fujisawa and Tani [26] which is based on the approximation that the fluid initial temperature is equal to surrounding temperature is utilized:

$$\eta_t = \eta_{el} + \left(1 - \frac{T_{amb}}{T_w}\right) \eta_{th} \quad (15)$$

where T_w is the water temperature evaluated from:

$$T_w = \frac{T_i + T_o}{2} \quad (16)$$

2.3. HCPV Electrical Model

Researchers presented various models in literature to determine I-V characteristics of multijunction solar cells as two diodes equivalent circuit model for each sub-cell, single diode equivalent circuit model for each sub-cell, lumped diode model and network cell model. The theoretical model stating the performance of solar cells should accurately determine the change of module energy with incident radiation, ambient temperature as well as cell concentration. In the present work, multijunction single diode model is adapted to develop a numerical model to express IV curve of the AZURSPACE triple-junction HCPV at different cell temperature, radiation intensity and concentration ratio. A single diode model provides accurate and dependable results while requiring less empirical factors to be determined, i.e. more practical and time saving than two diodes models where the empirical parameters of each sub-cell of the multi-junction solar cell must be calculated. **Figure 2** presents the diagram of single diode circuit model of the multijunction solar cells. Solar cell electrical model consists of current source that is a function of radiation in parallel with a diode. The model is expanded for concentrated cells to consider voltage difference caused by high current flow as a result of R_s . In addition, shunt resistance (R_{sh}) of diode commonly neglected in published models is considered in present developed model.

The triple junction solar cell consists of three junctions connected in series. Each junction expressed by single diode model. The current-voltage expression for each junction taking into consideration shunt resistance is given by:

$$I_i = I_{sc,i} - I_{o,i} \left[e^{\frac{q(V_i + I_i R_{s,i})}{n_i k_B T}} - 1 \right] - \frac{V_i + I_i R_{s,i}}{R_{sh,i}} \quad (17)$$

Every sub-cell utilizes five factors: saturation current ($I_{o,i}$), short circuit current (I_{sc}), series and shunt resistances $R_{s,i}$ and $R_{sh,i}$ as well as ideality factor of the diode (n). T is cell temperature, V is voltages, k_B is Boltzmann constant, electron charge is q , J_i is load current; and represent cell junction (1 for top cell, 2 for medium cell and 3 for bottom cell). Diode ideality factor, n , describes non-idealities in diffusion diode. Reverse saturation current (I_0) is the major parameter affecting V_{oc} which is losses indicator for minority carriers through p - n junction in reverse bias. Following on Shockley diodes theory ($n = 1$), however values of n greater than unity is much suitable to consider defects produced through industrial manufacturing. R_s is the addition of metal grids bulk resistance, bulk resistance of semiconductor materials and interconnections and resistance contacting metal contact and the semiconductor. Series resistance, R_s , is considered the most important parameter to achieve concentrated cells of enhanced performance. Shunt resistance is due to leakage current through p - n junction in cell boundary or in the crystal in the proximity to the junction

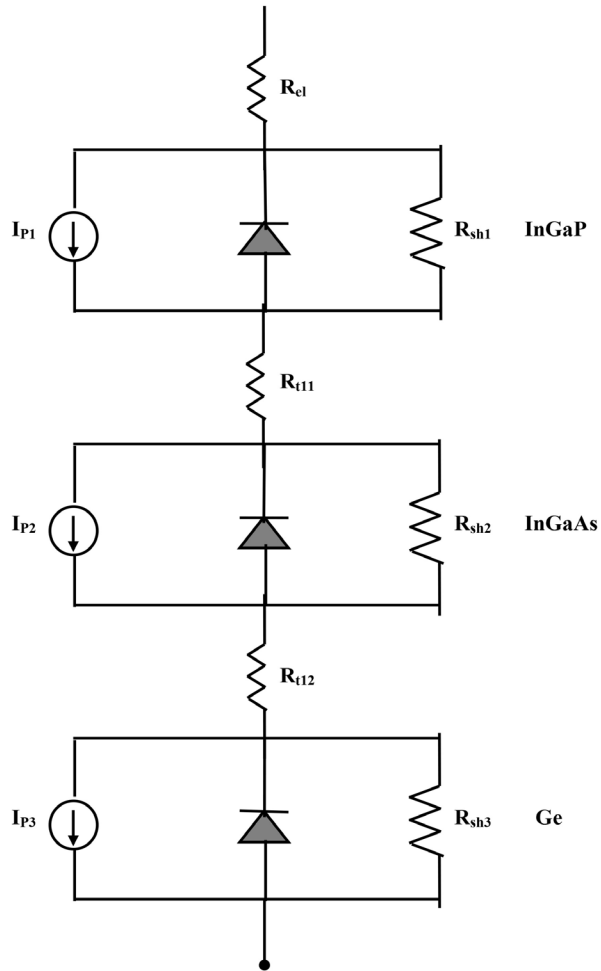

Figure 2. Triple junction single diode equivalent circuit.

because of imperfections or impurities deposition. V_{oc} is obtained by putting $I = 0$ in Equation (17).

Last term in Equation (17) makes the equation nonlinear and implicit requiring huge efforts to be solved. So, this term is commonly ignored in already existing models considering shunt resistance is equal infinity. This assumption significantly affects the accuracy of the results. That is why the present work considers the shunt resistance in calculations. Employing Lambert W-function, Equation (17) can be converted from implicit equation to explicit nonlinear equation. Jain and Kapoor [27] adapted Lambert W-function to rewrite Equation (17) as:

$$I_i = -\frac{V_i}{R_{s,i} + R_{sh,i}} - \frac{\text{Lambert W} \left\{ \frac{R_{sh,i} (R_{s,i} I_{sc,i} + R_{s,i} I_{o,i} + V_i)}{\frac{nk_{BT}}{q} (R_{s,i} + R_{sh,i})} \right\} \frac{nk_{BT}}{q}}{R_{s,i}} + \frac{R_{sh,i} (I_{o,i} + I_{sc,i})}{R_{s,i} + R_{sh,i}} \quad (18)$$

Because of the explicit aspect, Equation (18) has been employed to analyze HCPV systems [28] [29]. Maple software is utilized to perform calculations of current developed numerical model. Ghoneim *et al.* [30] introduced in detail the numerical technique adapted to analyze Equation (18). The solar radiation absorbed by HCPV cells, Q_{abs} is given by:

$$Q_{abs} = XGA_{rec} \eta_{op} \quad (19)$$

where G is the global radiation in (W/m^2); η_{op} is optical efficiency; A_{rec} is the receiver area and X is geometrical concentration ratio of HCPV optical system. The concentration ratio (X) is the receiver area (A_{rec}) divided by the concentrator aperture area (A_{ap}). The electrical efficiency (η_{el}) of triple-junction solar cells is function of both concentration ratio (X) and cell temperature (T_{pv}) and expressed as [31] [32] [33]

$$\eta_{el} = 0.298 + 0.0142 \ln X + [-0.000715 + 0.0000697 \ln X](T_{pv} - 298) \quad (20)$$

The optical, module and inverter efficiencies (η_{op} , η_{mod} , η_{inv}) are assumed to be constants. So, cell output power is:

$$P_{pv} = XGA_{pv} \eta_{op} \eta_{mod} \eta_{inv} \eta_{el} \quad (21)$$

where A_{pv} is the area of HCPV cell.

The electrical efficiency (η_{el}) of HCPV/T system is determined from:

$$\eta_{el} = \frac{P_{pv}}{A_{ap} G} = \frac{XGA_{pv} \eta_{op} \eta_{mod} \eta_{inv} \eta_{el}}{A_{ap} G} \quad (22)$$

The output power of HCPV reaches peak at maximum power point (MPP). Fill factor (FF) examines square similarity of IV as:

$$FF = \frac{P_m}{V_{oc} I_{sc}} = \frac{V_m I_m}{V_{oc} I_{sc}} \quad (23)$$

where I_m and V_m are maximum current and maximum voltage at maximum power P_m .

The short circuit current I_{sc} (X sun) is expressed as function of concentration ratio (X):

$$I_{sc}(X \text{ sun}) = XI_{sc}(1 \text{ sun}) \quad (24)$$

where $I_{sc}(1 \text{ sun})$ is the short circuit current at 1 sun and 1 sun equals 1000 W/m^2 . The models are examined utilizing measurement data provided by AZURSPACE manufacturer [34]. The developed model results agree well with measured values provided by AZURSPACE manufacturer. The total root mean square errors in the current results are approximately 1.94%.

3. Results and Discussions

The effect of the system important parameters namely ambient temperature (T_{amb}), cooling water temperature (T_w), cell temperature (T_{pv}) and concentrated ratio (X) on electrical, thermal and total efficiencies will be presented and discussed. Followed discussions and conclusions are extracted from the electrical and thermal models developed for this work.

3.1. Thermal Efficiency of Hybrid HCPV/T System

The main source of thermal energy in HCPV/T system is the overheated HCPV cell. A thermal model is developed for the hybrid HCPV/T system to calculate the thermal performance η_{th} utilizing finite difference technique for two-dimensional model. Applying energy balance for each system element, the impact of concentration ratio (X) and cooling water temperature (T_w) on the thermal efficiency (η_{th}) can be explored.

Figure 3 shows the impact of concentration ratio on the thermal efficiency at two different ambient temperatures 25°C and 45°C. As revealed by the figure, thermal efficiency rises slightly with increasing concentration ratio from 1 sun till about 400 suns then for higher concentration ratio the increase is faster. Increasing ambient temperature to 40°C, the thermal efficiency behaves in the same manner with about 10% higher in efficiency values. The variation of thermal efficiency versus concentration ratio is opposite to the behavior of electric efficiency at higher concentration levels ($X > 400$ suns). Also, this figure reveals that the HCPV/T system runs well in hot climates because of thermal efficiency increase with high ambient temperature for high concentration values.

Figure 4 illustrates the effect of cooling water temperature T_w on heat discharged from the of HCPV/T hybrid system which use active cooling method. **Figure 4** indicates the variation of thermal efficiency with cooling water temperature at three various concentration ratios 1sun, 500 suns and 1000 suns. As figure reveals, thermal efficiency of HCPV/T system decreases gradually from 40% to zero when increasing cooling water temperature from 20°C to 45°C for 1 sun concentration ratio, while increasing the concentration ratio to higher levels for example 500 suns or 1000 suns the thermal efficiency values drop to zero at higher water temperature 59°C and 77°C, respectively. This indicates that increasing X to higher levels (>400 suns) results in increasing the thermal efficiency to values higher than 65% and the cooling water could be heated to temperature higher than 75°C.

3.2. HCPV Cell Temperature

Based on the proposed curve fitting methods assuming wind speed is equal to zero and the cooling fluid temperature of HCPV is constant, the concentration ratio and the ambient temperature are regarded as the main source of cell temperature. The operating temperature of photovoltaic cell especially HCPV/T system strongly affects its performances. Therefore, the main absorber of the used multijunction solar cell is a semiconductor material with a band gap which is sensitive to the increase of cell temperature. The increase in cell temperature decreases the band gap which implies a decrease in some electrical parameters of the cell: open circuit voltage, fill factor and efficiency while increase the short circuit current. Since the temperature of cell is an important model parameter in examining the electrical and thermal behavior of HCPV cell and due to difficulty in measuring it there are several models employed to evaluate the temperature of

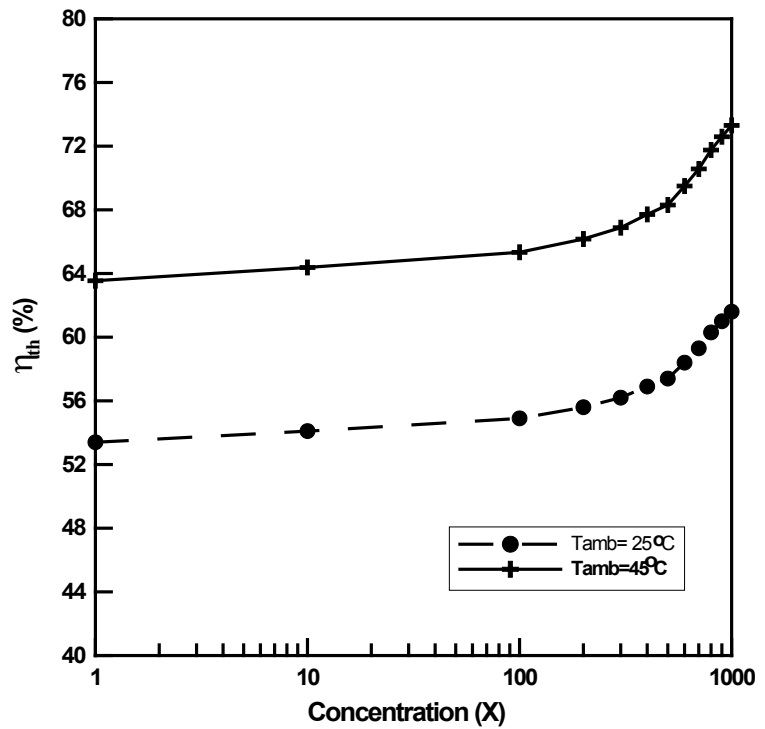

Figure 3. Thermal efficiency behavior with concentration ratio.

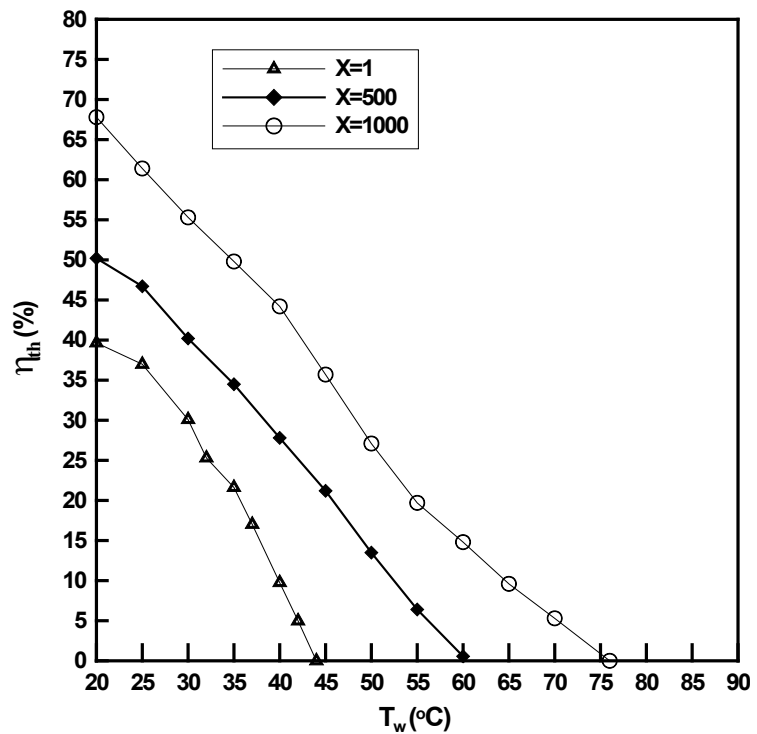

Figure 4. Thermal efficiency changes with cooling water temperature for various concentration ratio.

HCPV cell. Rodrigo *et al.* [35] introduced extensive analysis of calculating cell temperature for high concentrated modules based on direct measurements or

atmospheric parameters. They stated that some techniques are more suitable for specific conditions and examining the temperature of cell at maximum power point is useful for certain work and is interesting for future work.

In this research, the cell temperature is determined from the model proposed by introduced by Ju *et al.* [36]:

$$T_{PV} = T_{ref} + \frac{\left[V_{oc}(T_c, X) - V_{oc}(T_{ref}, 1) - \frac{nkT_{ref} \ln(X)}{q} \right]}{\beta_{Voc}(X)} \quad (25)$$

where β_{Voc} is the open circuit temperature coefficient and T_{ref} is the reference temperature.

Figure 5 illustrates the variation of cell temperature with the concentration ratio (X). The figure shows that the cell temperature rises logarithmically with the increase of the concentration ratio at a slow behavior up to X equal to about 400 suns then at higher concentration values up to X equal to 1500 suns, the increase becomes faster.

Figure 6 shows the variation of cell temperature with the ambient temperature. As figure shows, the cell temperature increases linearly faster with the increase of ambient temperature and this behavior depends on the location. These results agree with the outcomes of Renno *et al.* [8] and Skoplaki *et al.* [12]. **Figure 5** and **Figure 6** indicate that cell temperature (T_{pv}) is strongly dependent on ambient temperature (T_{amb}) and high concentration ratio (X) but in different manners.

3.3. Electrical Parameters of HCPV/T System

3.3.1. Effect of Cell Temperature on V_{oc} and FF

The variation of (V_{oc}) with the cell temperature (T_{pv}) at two different ambient temperatures T_{amb} (25°C and 45°C) are presented in **Figure 7**. As shown, cell temperature increases from 25°C to 70°C, V_{oc} reduces with a fixed slope. In addition, with increasing the ambient temperature to 45°C the same linear behavior is noticed with distinguished increase in the slope. This means that the temperature sensitivity increases with the increase of cell temperature which resulting due to the increase of concentration ratio. These results agree well with the corresponding results published in the literature [37] [38] for the triple junction solar cell. This decrease of V_{oc} with the increase of cell temperature and the ambient temperature results mainly because of the exponential increase of I_o with cell temperature. The most important characteristic of the figure is the capability of evaluating the temperature of hybrid HCPV/T under working conditions and standard conditions if the open circuit voltage is known.

Figure 8 presents the variation of FF with cell temperature for hybrid HCPV/T system at two different ambient temperatures 25°C and 45°C. The behavior is the same as for V_{oc} in **Figure 7** but with different explanation. FF is an indication of triple junction solar cell quality as it relies mainly on the parasitic

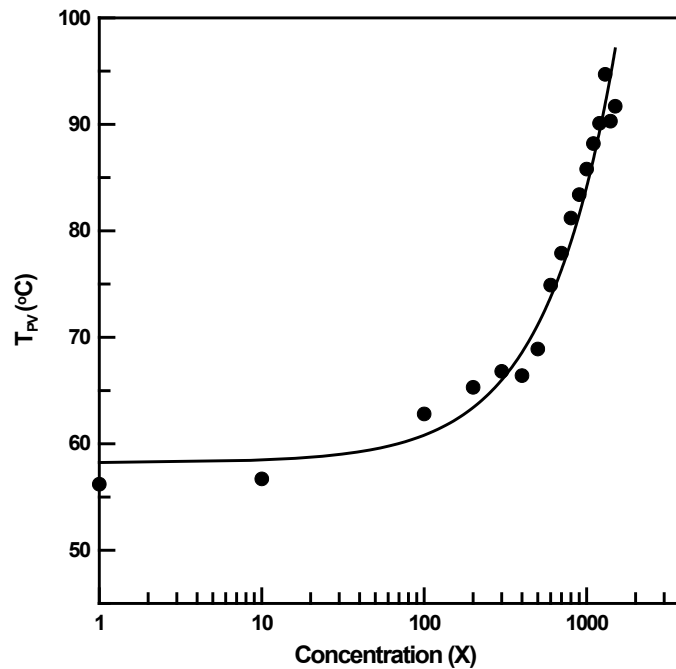

Figure 5. Variation of cell temperature versus concentration ratio.

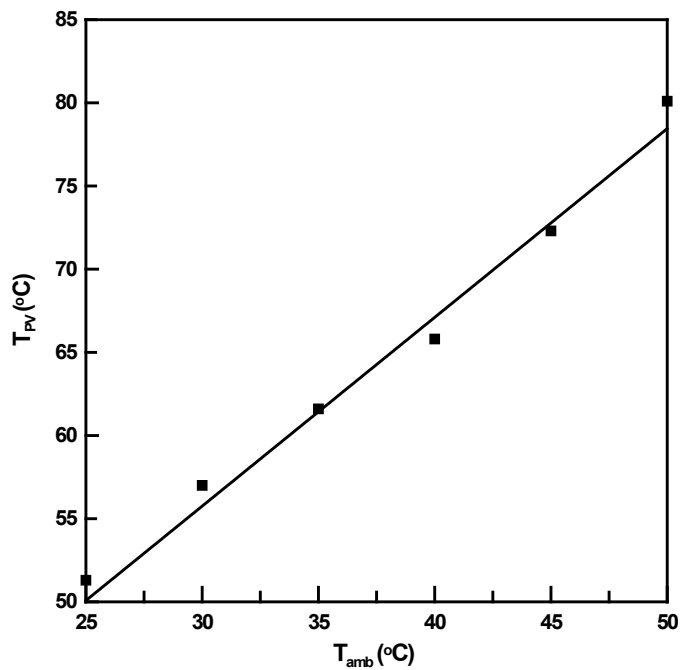

Figure 6. Variation of cell temperature against ambient temperature.

resistances of the cell. As the ambient temperature increases from 25°C to 45°C the FF values decrease in a linear form but with a higher slope. This decrease seems to be due to the increase in parasitic losses by increasing cell temperature and the increase of the slope is due to the increase of concentration ratio which induces increase of the cell ideality factor n as verified by electroluminescence study of the aged triple junction at high concentration values [8].

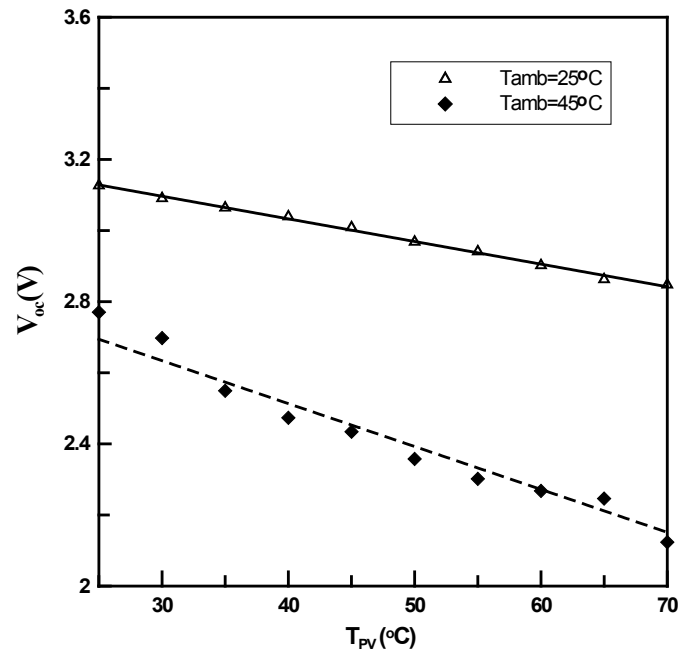

Figure 7. Change of open circuit voltage with cell temperature.

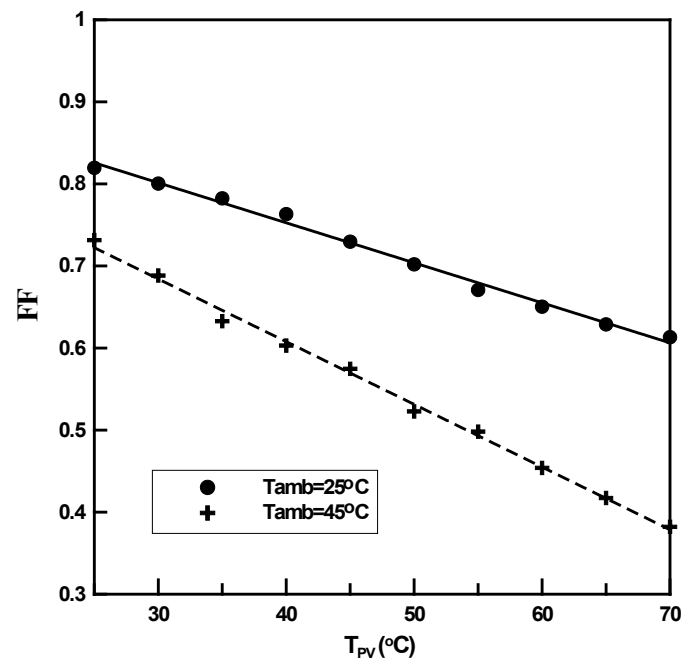

Figure 8. Variation of fill factor with cell temperature.

3.3.2. Effect of Concentration Ratio on Fill Factor and Electrical Efficiency

Figure 9 and **Figure 10** show the variation of both fill factor (FF) and cell electrical efficiency (η_{el}) with concentration ratio at two different cell temperatures 25°C and 80°C. **Figure 9** discussed in detail in literature [30]. As shown in these two figures the behavior of FF and η_{el} is similar; at cell temperature 25°C as the concentration values increase from 1 sun to about 400 suns the fill factor and the

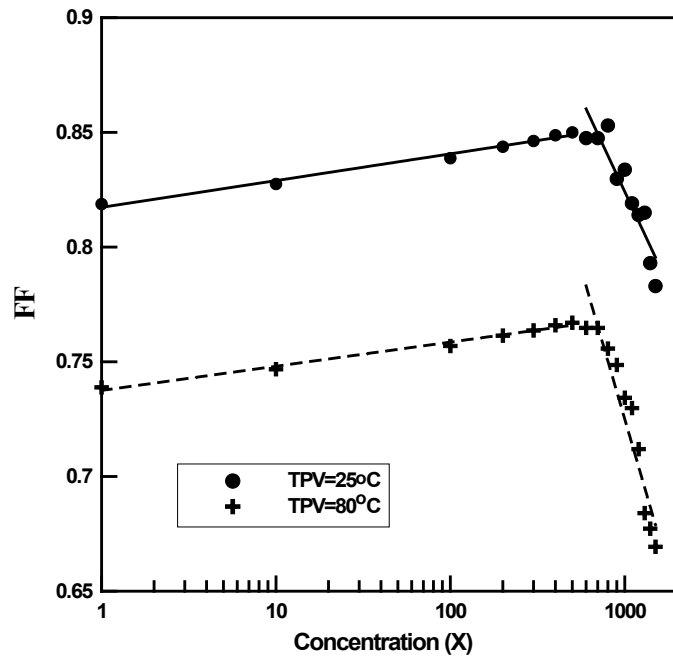

Figure 9. Change of fill factor with concentration ratio.

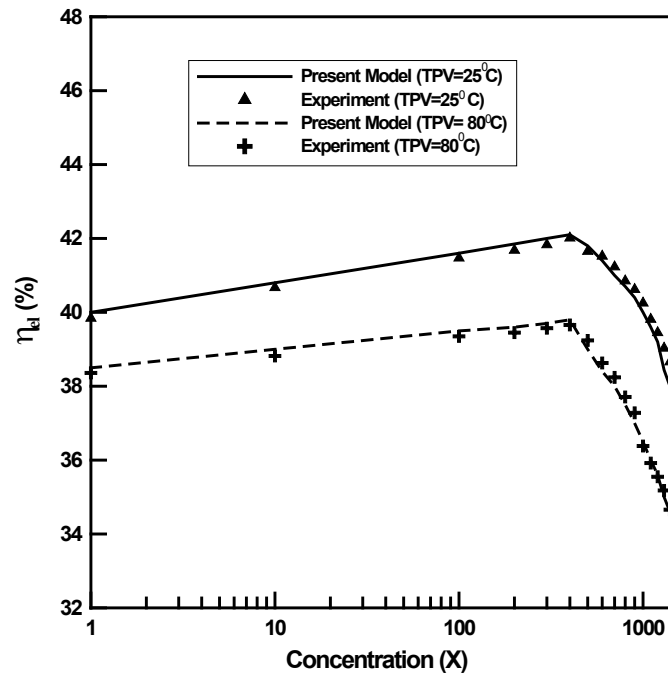

Figure 10. Variation of electrical efficiency with concentration ratio.

efficiency increase linearly from 0.82 to 0.85 for FF and from 40% 42.5% for η_{el} , then with increasing the concentration ratio higher than 400 suns there a drastically decrease of the two parameters to values 0.79 for FF and 38.5% for η_{el} which are still high values compared to other photovoltaic systems.

As cell temperature is raised from 25°C to 80°C the behavior is repeated for the FF and η_{el} but at lower values due to two reason; the overheating of the cell

and the high concentration ratio. As seen from these figures the increase of FF and η_{el} with increasing concentration ratio is slow at $X < 400$ suns and is faster for higher values of X . Also, the inverted peak in the two figures is slightly shifted to higher values of X . This may be due to the effect of increasing concentration ratio which means the light flux density increases, so the photogenerated current increases and the series resistance decreases. For higher values there is an extra heating of HCPV cell because of the increase of radiation flux. This overheating causes changes of the recombination processes of the photogenerated current carriers from radiative recombination to non-radiative type. The change of recombination process by overheating causes an increase parasitic electric loss due to an increase of R_s and decrease of R_{sh} photovoltaic device. So, the overheating is a significant problem for HCPV/T systems, and it can be solved utilizing suitable heat dissipation method in the hybrid system with active cooling and using this heat for certain application.

3.4. Electrical, Thermal and Total Efficiency of HCPV/T Hybrid System

The electrical, the thermal and the total efficiencies are calculated adapting the present developed model, as a function of the three important key parameters of HCPV/T hybrid unit; the concentration ratio, PV temperature and the ambient temperature. **Figure 11** illustrates the impact of concentration level X on system performances; electrical η_{el} , thermal η_{th} and the total efficiencies η_t at ambient temperature $T_{amb} = 25^\circ\text{C}$. This figure reveals that increasing the concentration ratio from 1 sun till 400 suns will increase both electrical η_{el} and thermal η_{th} efficiencies by about 2% and 3%. When increasing the concentration ratio to higher levels (>400 suns), there is a different behavior as the electrical efficiency η_{el} decreases by about 4% while the thermal efficiency η_{th} increases by about 10%. This behavior is reflected on the total efficiency η_t of the HCPV/T system as its value is about 72% at 1 sun and about 79% at 1500 suns, which is a good quantity to be collected from the incident solar power.

Figure 12 illustrates the variation of electrical, thermal and total efficiency with cell temperature (T_{pv}) at concentration ratio of 500 suns when cell temperature is increased from 45°C to 85°C . This figure shows that with the existence of active cooling device in HCPV/T unit, increasing cell temperature has no significant effect on the electrical efficiency as it reduces only by about 1%. However, this leads to significant increase of about 15% in thermal efficiency and increase of about 10% in total efficiency. This increase of the cell temperature may be attributed to slow flow rate of cooling water or heat leakage and imperfect insulation.

Figure 13 indicates the effect of ambient temperature T_{amb} on the three efficiencies of the HCPV/T hybrid system at a constant concentration level of $X = 500$ suns. The impact of ambient temperature on electrical, thermal and total efficiencies is the same as the effect of cell temperature T_{pv} discussed before in **Figure 12**.

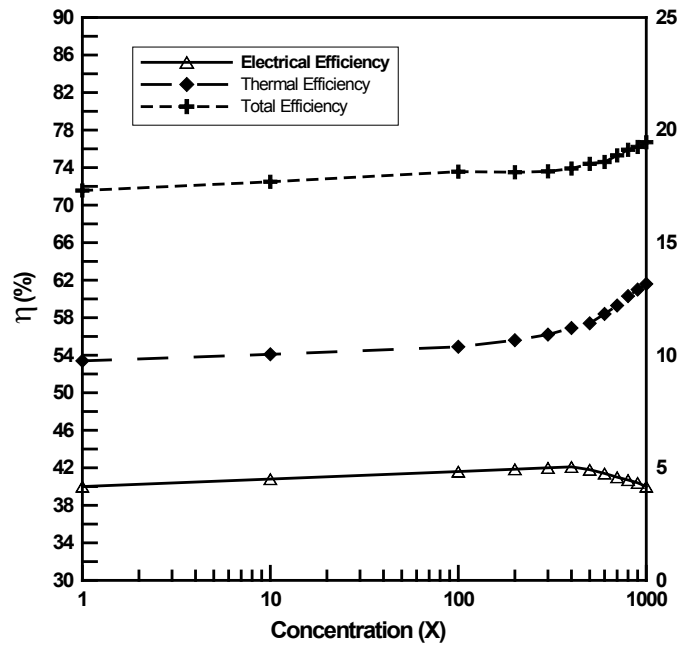

Figure 11. Electrical, thermal and total efficiency variation with concentration ratio.

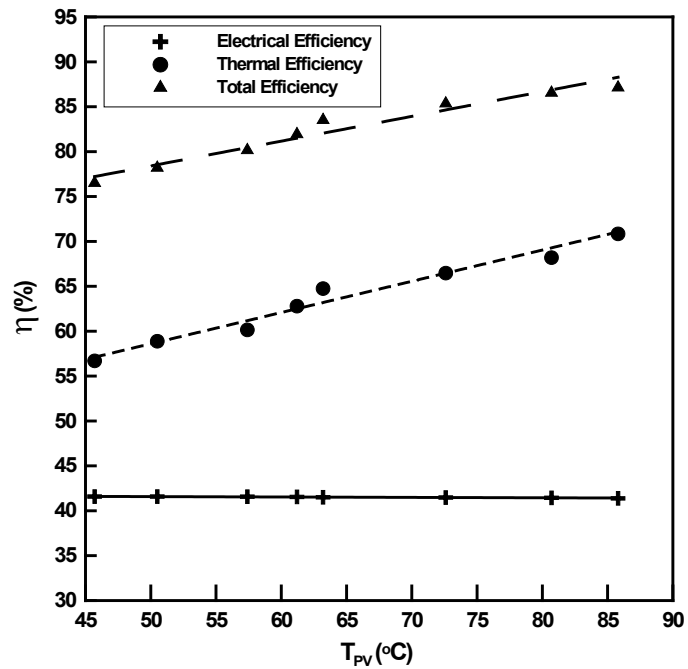

Figure 12. Variation of electrical, thermal and total efficiencies versus cell temperature.

4. Conclusions

The performance of high concentrating photovoltaic thermal (HCPV/T) system is examined. Single diode circuit model is employed to analyze the electrical performance of triple junction solar cells. Furthermore, a thermal model using two-dimensional finite difference technique is developed to determine the

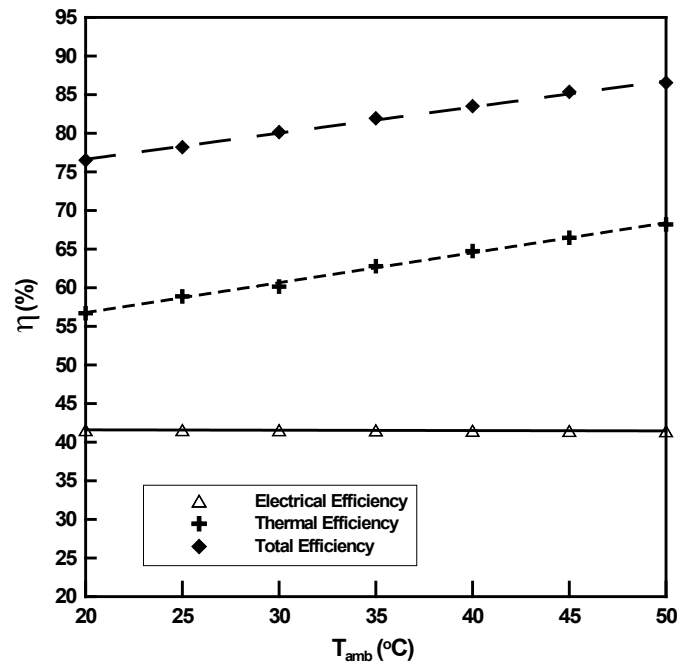

Figure 13. Variation of electrical, thermal and total efficiencies against ambient temperature.

thermal and total efficiency of hybrid HCPV/T system. Based on the results obtained, the following conclusions can be drawn:

- Single diode model is a reliable model instead of using the more complex model of two diodes. Overall root mean square errors in present results are about 1.942% as compared to HCPV cell manufacturer measurements.
- Single diode model can be utilized to precisely evaluate electrical performance of HCPV for a broad band value of operating parameters.
- Increasing the concentration ratio results in logarithmic rise in HCPV cell temperature at a slow rate up to concentration ratio about 400 suns, and then the increase becomes faster at higher concentration values up to $X = 1500$ suns.
- Cell temperature is strongly dependent on ambient temperature and concentration ratio but in different manners.
- Increasing the ambient temperature leads to a decrease in fill factor in a linear form with a higher slope.
- Overheating is a significant problem in HCPV/T systems, however, it can be resolved by introducing adequate heat removal techniques with active cooling.
- Hybrid HCPV/T system works efficiently in hot climates due to the increase of the system thermal efficiency with high ambient temperature at high levels of concentration.
- Increasing coolant water temperature significantly minimizes the thermal efficiency at low concentration ratio. On the other hand, at high values of concentration ratio (>400 suns), the thermal performance increases up to

65% and the coolant water temperature could be heated up to 75°C.

- When the concentration ratio increases to values greater than 400 suns, the electrical efficiency decreases by about 4% while the thermal efficiency increases by about 10%. This behavior has a significant effect on HCPV/T total efficiency.
- Employing active cooling device in HCPV/T system results in significant increase (about 15%) in thermal efficiency and at the same time leads to an increase of about 10% in total efficiency.
- The impact of ambient temperature on thermal, electrical and total efficiency is similar to the effect of cell temperature on these parameters.

The present work could be extended in the future by designing and setting up a practical HCPV/T system to carry out experimental work to validate the results obtained from theoretical work.

Acknowledgements

Financial support of the Public Authority for Applied Education and Training (PAAET), Kuwait during this research is greatly appreciated.

Conflicts of Interest

The authors declare no conflicts of interest regarding the publication of this paper.

References

- [1] Philipps, S.P., Bett, A.W., Horowitz, K. and Kurtz S. (2015) Current Status of Concentrator Photovoltaic (CPV) Technology. Fraunhofer ISE/NREL Report.
- [2] Maghanki, M.M., Ghobadian, B., Najafi, G. and Galogah, R.J. (2013) Micro Combined Heat and Power (MCHP) Technologies and Applications. *Renewable and Sustainable Energy Reviews*, **28**, 510-524. <https://doi.org/10.1016/j.rser.2013.07.053>
- [3] Raj, N.T., Iniyar, S. and Goic, R. (2011) A Review of Renewable Energy-Based Cogeneration Technologies. *Renewable and Sustainable Energy Reviews*, **15**, 3640-3648. <https://doi.org/10.1016/j.rser.2011.06.003>
- [4] Chemisana, D. Building Integrated Concentrating Photovoltaics: A Review. (2011) *Renewable and Sustainable Energy Reviews*, **15**, 603-611. <https://doi.org/10.1016/j.rser.2010.07.017>
- [5] Renno, C., Petito, F., Landi, G. and Neitzer, H.C. (2017) Experimental Characterization of Concentrating Photovoltaic System Varying the Light Concentration. *Energy Conversion and Management*, **138**, 119-130. <https://doi.org/10.1016/j.enconman.2017.01.050>
- [6] Higuera, P.P., Rodriguez, J.P.F. Almonacid, F. and Fernandez, E.F. (2018) Efficiency and Acceptance Angle of High Concentrated Photovoltaic Modules: Current Status and Indoor Measurements. *Renewable and Sustainable Energy Review*, **94**, 143-153. <https://doi.org/10.1016/j.rser.2018.06.011>
- [7] Shanks, K., Senthilarasu, S. and Mallick, T.K. (2016) Optics for Concentrated Photovoltaics: Trends, Limits and Opportunities for Materials and Design. *Renewable and Sustainable Energy Review*, **60**, 394-407.

- <https://doi.org/10.1016/j.rser.2016.01.089>
- [8] Renno, C., Landi, G. Petito, F. and Neitzert, H.C. (2018) Influence of a Degraded triple-Junction Solar Cell on the CPV System. *Energy Conversion and Management*, **160**, 326-340. <https://doi.org/10.1016/j.enconman.2018.01.026>
- [9] De Feo, G., Forni, M., Petito, F. and Renno, C. (2016) Life Cycle Assessment and Economic Analysis of Low Concentrated Photovoltaic System. *Environmental Technology*, **37**, 2473-2482. <https://doi.org/10.1080/09593330.2016.1152308>
- [10] Araki, K., Yano, T. and Kuroda, Y. (2010) 30 kW Concentrator Photovoltaic System Using Dome-Shaped Fresnel Lenses. *Optics Express*, **18**, A53-A63. <https://doi.org/10.1364/OE.18.000A53>
- [11] Xie, W.-T., Dai, Y.-J., Wang, R.-Z. and Sumathy, K. (2011) Concentrated Solar Energy Applications Using Fresnel Lenses: A Review. *Renewable and Sustainable Energy Reviews*, **15**, 2588-2606. <https://doi.org/10.1016/j.rser.2011.03.031>
- [12] Skoplaki, E. and Palyvos, J.A. (2009) On the Temperature Dependence of Photovoltaic Module Electrical Performance: A Review of Efficiency/Power Correlations. *Solar Energy*, **83**, 614-624. <https://doi.org/10.1016/j.solener.2008.10.008>
- [13] Nishioka, K., Takamoto, T., Agui, T., Kaneiwa, T., Uraoka, M. and Fuyuki, Y.T. (2015) Evaluation of Temperature Characteristics of High-Efficiency InGaP/InGaAs/Ge Triple-Junction Solar Cell under Concentration. *Solar Energy Materials and Solar Cells*, **85**, 429-436. <https://doi.org/10.1016/j.solmat.2004.05.008>
- [14] Royne, A., Dey, C.J. and Mills, D.R. (2005) Cooling of Photovoltaic Cells under Concentrated Illumination: A Critical Review. *Solar Energy Materials and Solar Cells*, **86**, 451-483. <https://doi.org/10.1016/j.solmat.2004.09.003>
- [15] Perez-Higueras, P., Munoz, E., Almonacid, G. and Vidal, P.G. (2011) High Concentrator Photovoltaics Efficiencies: Present Status and Forecast. *Renewable and Sustainable Energy Reviews*, **15**, 1810-1815. <https://doi.org/10.1016/j.rser.2010.11.046>
- [16] Jakhar, S., Soni, M.S. and Gakkhar, N. (2016) Historical and Recent Development of Concentrating Photovoltaic Cooling Technologies. *Renewable and Sustainable Energy Review*, **60**, 41-59. <https://doi.org/10.1016/j.rser.2016.01.083>
- [17] Or, B.A. and Appelbom, J. (2014) The Dependence of Multijunction Solar Cell Parameters on Concentration and Temperature. *Solar Energy Materials and Solar Cells*, **130**, 234-240. <https://doi.org/10.1016/j.solmat.2014.07.010>
- [18] Xu, N., Ji, J., Sun, W., Huang, W., Li, J. and Jin, Z. (2016) Numerical Simulation and Experimental Validation of High Concentration Photovoltaic/Thermal Module Base on Point Focus Fresnel Lens. *Applied Energy*, **168**, 169-281. <https://doi.org/10.1016/j.apenergy.2016.01.077>
- [19] Sharaf, O. and Orhan, M.F. (2015) Concentrated Photovoltaic Thermal (CPVT) Solar Collector Systems: Part II—Implemented Systems, Performance Assessment and Future Directions. *Renewable and Sustainable Energy Review*, **50**, 1566-1633. <https://doi.org/10.1016/j.rser.2014.07.215>
- [20] Ju, X., Xu, C., Han, X., Du, X., Wei, G.-S. and Yang, Y.-P. (2017) A Review of the Concentrated Photovoltaic/Thermal System (CPVT) Hybrid Solar Systems Based on the Spectral Beam Splitting Technology. *Applied Energy*, **187**, 534-563. <https://doi.org/10.1016/j.apenergy.2016.11.087>
- [21] Klein, S.A., et al. (2018) TRNSYS, a Transient System Simulation Program Manual, Solar Energy Laboratory, University of Wisconsin-Madison.
- [22] Incropera, F.P., Dewitt, D.P., Bergman, T.L. and Lavine, A.S. (2007) Fundamentals of Heat and Mass Transfer. John Wiley & Sons Inc., Hoboken, NJ.

- [23] Duffie, J.A. and Backman, W.A. (2013) *Solar Engineering of Thermal Processes*. John Wiley & Sons, Inc., Hoboken, NJ. <https://doi.org/10.1002/9781118671603>
- [24] Ji, J., Lu, J.P., Chow, T.T., He, W. and Pei, G. (2007) A Sensitivity Study of a Hybrid Photovoltaic/Thermal Water-Heating System with Natural Circulation. *Applied Energy*, **84**, 222-237. <https://doi.org/10.1016/j.apenergy.2006.04.009>
- [25] Chow, T.T., Pei, G., Fong, K.F., Lin, Z., Chan, A.L.S. and Ji, J. (2009) Energy and Exergy Analysis of Photovoltaic-Thermal Collect with and without Glass Cover. *Applied Energy*, **86**, 310-316. <https://doi.org/10.1016/j.apenergy.2008.04.016>
- [26] Fujisawa, T. and Tani, T. (1997) Annual Exergy Evaluation on Photovoltaic-Thermal Hybrid Collector. *Solar Energy Materials and Solar Cells*, **47**, 135-148. [https://doi.org/10.1016/S0927-0248\(97\)00034-2](https://doi.org/10.1016/S0927-0248(97)00034-2)
- [27] Jain, A. and Kapoor, A. (2014) Exact Analytical Solutions of the Parameters of Real Solar Cells Using Lambert W-Function. *Solar Energy Materials and Solar Cells*, **81**, 269-277. <https://doi.org/10.1016/j.solmat.2003.11.018>
- [28] Ghani, F. and Duke, M. (2011) Numerical Determination of Parasitic Resistances of a Solar Cell Using the Lambert W-Function. *Solar Energy*, **85**, 2386-2394. <https://doi.org/10.1016/j.solener.2011.07.001>
- [29] Ghani, F., Rosengarten, G., Duke, M. and Carson, J.K. (2015) On the Influence of Temperature on Crystalline Silicon Solar Cell Characterization Parameters. *Solar Energy*, **112**, 437-445. <https://doi.org/10.1016/j.solener.2014.12.018>
- [30] Ghoneim, A.A., Kandil, M.K., Alzanki, T.H. and Alenezi, M.R. (2018) Performance Analysis of High Concentrated Multi-Junction Solar Cells in Hot Climate. *International Journal of Sustainable Energy*, **37**, 294-310. <https://doi.org/10.1080/14786451.2016.1270284>
- [31] Li, M., Xu, J., Li, G.-L., Wei, S.-X., Li, Y.-F. and Shi, F. (2011) Performance Study of Solar Cell Arrays Based on a Trough Concentrating Photovoltaic/Thermal System. *Applied Energy*, **88**, 3218-3227. <https://doi.org/10.1016/j.apenergy.2011.03.030>
- [32] Calise, F. and Vanoli, L. (2012) Parabolic Trough Photovoltaic/Thermal Collectors: Design and Simulation Model. *Energies*, **5**, 4186-4208. <https://doi.org/10.3390/en5104186>
- [33] Buonomano, A., Calise, F., Dentice, M. and Vanoli, L.A. (2013) A Novel Solar Tri-generation System Based on Concentrating Photovoltaic/Thermal Collectors. Part 1: Design and Simulation Model. *Energy*, **61**, 59-71. <https://doi.org/10.1016/j.energy.2013.02.009>
- [34] Azur Space Solar Power (2019) <http://www.azurspace.com/index.php/en/>
- [35] Rodrigo, P., Fernandez, E.F., Almonacid, F. and Perez-Higueras, P.J. (2014) Review of the Methods for the Calculation of Cell Temperature in High Concentration Photovoltaic Modules for Electrical Characterization. *Renewable and Sustainable Energy Reviews*, **38**, 478-488. <https://doi.org/10.1016/j.rser.2014.06.008>
- [36] Ju, X., Vossier, A., Wang, Z., Dollet, A. and Flamant, G. (2013) An Improved Temperature Estimation Method for Solar Cells Operating at High Concentrations. *Solar Energy*, **93**, 80-89. <https://doi.org/10.1016/j.solener.2013.02.028>
- [37] Helmers, H., Schachtner, H. and Bett, A.W. (2013) Influence of Irradiance Ant Temperature on Triple-Junction Solar Subcells. *Solar Energy Materials and Solar Cells*, **116**, 144-152. <https://doi.org/10.1016/j.solmat.2013.03.039>
- [38] Cotal, H., Fetzer, C., Boisvert, J., Kinsey, G., King, R., Hebert, P., Yoon, H. and Karam, N. (2009) III-V Multijunction Solar Cells for Concentrating Photovoltaics. *Energy and Environmental Science*, **2**, 174-192. <https://doi.org/10.1039/B809257E>