

Fuzzy Modelling for Qatar Knowledge-Based Economy and Its Characteristics

Tameur Nacheft¹*, Muhamad Bin Jantan², Abdelmalek Boularas³

¹Imperial Training and Consulting (*IMPERIAL-TC*), Doha, Qatar

²Universiti Sains Malaysia, Penang, Malaysia

³Ahmed Bin Mohammed Military College, Doha, Qatar

Email: tameur@imperial-tc.com, muhamad.jantan@gmail.com, aboularas@gmail.com

Received 7 January 2014; revised 7 February 2014; accepted 14 February 2014

Copyright © 2014 by authors and Scientific Research Publishing Inc.

This work is licensed under the Creative Commons Attribution International License (CC BY).

<http://creativecommons.org/licenses/by/4.0/>



Open Access

Abstract

This paper aims to present an overview of the framework and methodology that might help Qatari decision makers understand and identify factors affecting the transition towards a knowledge-based economy in a non-static fast-changing real-world setting, with a specific focus on clarifying some of the key dynamics and characteristics of its establishment. In this regards, it aims to quantify the effect of government policies, ICT infrastructure, and society norm dimensions by seeking to provide an insight on the main driving forces behind its emergence—exploring the core pillars, potential pitfalls, and bottlenecks. In addition, it attempts to help close the existing gaps resulting from the discrepancy between the pace of the knowledge-based economy foundation and inadequate supporting institutional framework. Country-specific characteristics of the Qatar economy are considered in order to determine the right approach for adopting the knowledge-based economy orientation that would be aligned with Qatar National Vision 2030. Finally, the expert-driven fuzzy-logic approach has been proposed to help decision-makers in providing guidance for outlining and evaluating the relevant strategies.

Keywords

Knowledge-Based Economy; Qatar Economy Characteristics; Fuzzy Modelling Approach

1. Introduction

The last couple of decades have been characterized by the rapid transformation of economic concepts that have had profound influence on the establishment of innovation-driven economies. In particular, it has been identified

*Corresponding author.

that the transition from an oil-based to a knowledge-based economy, for Qatar, would decrease the country's economic reliance on exploitation of hydrocarbon resources and contributes to its diversification and establishment of long-term sustainable business environment.

The main aim of this paper was to outline the most effective model that would help Qatari decision-makers evaluate their efforts towards predetermined knowledge-based economy establishment goals.

The paper starts with an in-depth discussion on the relevant knowledge-based economy determinants. Furthermore, the underlying pillars and initiator factors pertaining to knowledge-economy establishment and the associated bottlenecks are scrutinized in greater detail to help understand potential challenges that might be encountered during the transition stage. Subsequently, country-specific characteristics of Qatari economy are considered to help determine the most adequate approach for adopting the knowledge-based economy framework aligned with the Qatar National Vision 2030. In that regards, the expert-driven fuzzy-logic methodology has been proposed to test the suggested research model that aims to quantify the effect of government policies, ICT infrastructure, and society norm dimensions on influencing decision making in a transition towards knowledge-based economy. Following a detailed discussion on the research model stages and their associated factors, the paper outlines the benefits resulting from the utilization of the proposed methodology with a recommendation for further model development to evaluate the knowledge-based economy level. It is worthy in this regards to mention that this paper is a conceptual paper, where the authors are inviting researcher to apply the developed model and proposed methodology for factors evaluation.

2. Pillars of a Knowledge-Based Economy

The developed economies are characterized by investments in knowledge and information as these are recognized as the primary drivers of productivity and the engine of economic growth. Along with knowledge investments, economic performance is affected by knowledge dissemination across formal and informal networks.

The emphasis on knowledge, information, and technology in the context of economic performance has been analysed with the intention to better understand the underlying forces of knowledge-based economy. With increasing knowledge codification and its transmission via communications and computer networks, the concept and the importance of continuous learning has become essential in ensuring sustainable economic success. In the knowledge-based economy, the traditional linear model of innovation has been replaced by a more interactive one, where innovation is stimulated by the exchange of knowledge [1]. Innovation is therefore derived as an outcome of numerous interactions between groups of relevant factors and institutions, which together constitute the national innovation system [2].

The structures of these systems are comprised of relationships between industry, science, and government in relation to the development of the relevant knowledge base which constitute an important economic determinant that influences the innovative performance of economies [3]. Gradually, these innovation systems have been extended beyond national borders and assumed more international dimension, whereas the “knowledge distribution power” has become the vital consideration signifying the ability of innovators to access pertinent stocks of knowledge in a timely manner [4]. In that regards, the essential issues that are being raised concern the role of national governments and policy makers in the knowledge base development and maintenance. Following that line of thought, the identified policies and approaches towards knowledge-based economy that is based on production, dissemination, and economic use of knowledge should be framed to maximize economic performance and welfare of the society.

The country's science structure, made up of public research and higher education institutes, has an important function in the knowledge-based economy in relation to the production and dissemination of knowledge. Contrary to its traditional function where the generation of new knowledge is accomplished solely through basic research activities, the science system in knowledge-based economy has a more profound and collaborative role with the industry in driving the knowledge, which is characterized by three pillars. 1) Production, which is generating and providing new knowledge. 2) Transmission refers to educating and developing human capital, and 3) Transfer, which means distributing knowledge and technology that contribute to problem solving [4]. Thus, the trend of R&D institutes and academia partnering with the industry for innovative purposes has become increasingly relevant.

To better facilitate economic analysis, [5] have distinguished between four different components of knowledge that are relevant for the knowledge intensive economies, namely “*know what*”—referring to information and knowledge about facts, “*know why*”—implying the scientific knowledge originating from research institutes

and universities that is driving the technological development, “*know how*”—denoting the skills and abilities to perform something in a manner that is causing superior results, and “*know who*”—referring to the information on who knows what, as well as how to do something. The last two categories of “*know how*” and “*know who*” are more tacit in nature, and therefore not easy to codify and measure. While the “*know how*” represents one of the key reasons for industrial networks establishment that is crucial to expanding the innovative capacities, the “*know who*” type of knowledge refers to development of social relationships that can provide the access to required experts and their knowledge, which is increasingly becoming important due to prevailing economic conditions and the accelerated pace of change.

Mastering the four identified categories of knowledge occurs throughout different channels. Although the first two components can be acquired by reading books, attending lectures, and accessing databases, the “*know how*” and “*know who*” are more related to practical experiences [5]. In that respect, the information and Communication Technology (ICT) development is attributable to fulfilling the need for managing more effectively the “*know what*” and “*know why*” knowledge. On the other hand, the existence of ICT and associated infrastructures has provided a strong incentive to codification of certain elements of knowledge that could be reduced to information and transmitted at little cost [2]. As a result of this codification, knowledge was able to take up the characteristics of a commodity and become the subject of market transactions, which further affected the increase of knowledge dissemination rates. Moreover, the codification has decreased the knowledge dispersion and importance of further investment in obtaining additional knowledge.

Despite the impact of ICT on shifting the boundary between codified and tacit knowledge, in knowledge-based economy, continuous learning of codified information along with the abilities to make the use of this information is equally important [6]. With reduced costs and easier access to information, the competencies relevant to its efficient selection and use are becoming even more critical. This tacit knowledge and the associated abilities to select relevant and disregard irrelevant information, as well as to interpret it, can only be acquired through learning and education, which represent the focal point in knowledge-based economies. In this context, learning represents a much more inclusive category that just obtaining formal education and it has to account for the “*learning by doing*” aspect, which refers to the ability to transform the tacit knowledge into codified, and vice versa [6]. In that way, new categories of tacit knowledge are being constantly created. For that reason, the lack of investments in human resources and their codified and tacit abilities development may hinder the economic efficiency of markets [3].

In knowledge intensive economies, effective dissemination and the use of knowledge is of great importance and one of the key determinants for success of national economies that are becoming a hierarchy of strategic networks where the accelerated degree of change creates the need for establishment of network societies [7]. The related ability to join these knowledge and learning networks affects the socio-economic position of individual members, organizations, and national economies [2]. In fact, the network aspect of the knowledge intensive economies came forward with the changes in a traditional linear model of innovation that observed innovation as a linear process of discovery stages where scientific research was the initial phase and the driving force behind innovation [8]. In the knowledge-based economy, innovation is a result of interactions between different disciplines and participants, such as organizations, research institutes, academia and science, consumers, product development, manufacturing, engineering, etc. It can assume various forms from basic advancements to existing products, to employing existing technologies to new markets and introducing new technologies to existing markets. Furthermore, productivity and growth are mostly affected by the degree of technological progress and knowledge accumulation capacity [3]. In addition, these knowledge intensive segments of the economy have a tendency to generate increased output and employment growth. In that regards, knowledge and learning networks act as core mechanisms for efficient knowledge and information dissemination that are preconditioned for long-term economic growth.

In addition to promoting internal interactive learning, organizations are searching for external partners and access to networks in order to spread the innovation risks and the associated costs, to obtain expertise for new technological processes and products, and to get first-hand access to up-to-date research results [4]. Throughout that process, organizations decide which of these activities they can carry out individually and which they will need to undertake in collaboration with different partners.

Overall, knowledge-based economy could be seen as a composition of “*know what*”, “*know why*”, “*know how*” and “*know who*”. Those components should be linked in communication infrastructure to facilitate its dissemination, sharing and utilization within an economical system governed by a set of state policies, qualified

human capital, and a knowledge-based economic trading system to generate a surplus for the economy. The following sections cover the knowledge-based economic initiator factors in more holistic view.

3. The Initiator Factors of Knowledge-Based Economy and Its Bottleneck

In the knowledge-based economy, government policies pertaining to education and science, as well as industry and technology, would have to account for the pivotal role of organizations, the significance of national innovation systems, and the need for development of supporting infrastructure and the incentives for investments in R&D [6]. The priorities would have to be set to enhance the knowledge diffusion, upgrade human capital, and promote organizational change capacities. Encouraging the innovation would need to entail creating a framework that would facilitate the cooperation among industry, university and government, as well as promote the flow of new technologies to different industries. Moreover, government policies would need to be designed to enable the matching of demand and supply in terms of competencies requirements, providing up-to-date formal education and establishing incentives for life-long learning and continuous acquisition of new skills, on an organizational level. Furthermore, to be able to convert the technological advancements into productivity gains, a set of financial, competition, and information government policies would need to be established to provide the enabling conditions and infrastructure for increasing the flexibility to adapt to various forms of changes [6]. Furthermore, *national science and technology system* plays a crucial role in a knowledge-based economy through its core pillars comprised of higher education institutions and public research institutes that are governed by the supporting structure of science ministries and research councils. Moreover, it represents an integral part of the wider knowledge network that directly contributes to the production, transmission, and transfer of knowledge [4]. Traditionally, the science system has been regarded as the main engine for producing the new knowledge generally labelled as “science”, whereas the knowledge originating from the applied industry research was usually categorized as “technology”. Within the knowledge intensive economies, the difference between scientific and industry research has become somewhat difficult to distinguish, causing the debate on whether the scientific research is the only generator of new knowledge and what should be the corresponding role of national governments in providing financial and other support to relevant parties [8].

Scientific knowledge is thought to be the knowledge component that should not be held by a single member or a group but instead it should be considered as a public good and widely disseminated among all the concerned members of the society and, as such, providing a fundamental base for the technological knowledge development [2]. The public good quality of the scientific knowledge implies that it is prone to under-investment from the private sector. Thus, the government has to step in with various forms of subsidies to stimulate the scientific knowledge creation in order to improve the society welfare [6].

It has been argued that methods of scientific research have been extensively dispersed across the society due to previous investments in education and research. Consequently, both public and private research venues can be considered as potential initiating points for scientific knowledge [8]. Moreover, scientific and technological knowledge can now be produced as a result of collaborative research activities. Nowadays, technological progress is based on scientific input and, likewise, new scientific research is stimulated by the search for innovative technological solutions. Accordingly, the traditional foundations of the science system no longer hold the supremacy over the scientific knowledge production. The private sector, regardless of the likelihood of knowledge spill overs, has an interest to invest in basic public research activities as long as they can secure enough value from its utilization [4]. Following this line of thought, the government policies need to account for all the possible interactions in the creation of scientific knowledge and to revise the associated role of public support. However, the public investment in basic research activities should not be abandoned or decreased even in the presence of the private sector investments [6]. It should be noted that there are some doubts regarding the industry capacity to conduct sufficient volume of strictly fundamental research as their research efforts tend to be driven by their individual organization’s needs. Most of the industry R&D spending falls into the product development category where some of its portion is going to the applied research, while very little importance, in terms of investments, is given to the basic research activities [8]. Thus, there are valid concerns if adequate scientific knowledge would be created in the absence of public support and subsidies. Furthermore, international collaborative efforts in basic scientific research are encouraged that would further allow for the economic utilization of resources and realization of scale benefits. In the context of knowledge-based economy, countries that fail to invest in the generation of scientific knowledge would not be able to sustain the economic growth [4].

Another important role of the science system in the knowledge-based economy is that in the knowledge

transmission through universities has the vital role in education and training and providing the venues for mastering the new skills that would allow for the effective utilization of new technologies, as well as the continued production of scientific and technological knowledge. For that reason, human capital development in public and private institutions and universities is critical for the science system maintenance and it needs to keep up with the development of researchers in the private sector [3]. The constraints imposed by insufficient research budgets of public institutions have been increased by the problem of balancing between qualities versus quantities in terms of having to provide a broad based education to a growing number of people. These public institutions are encountering the requirements to carry on with the high quality research provision while, at the same time, having to accommodate the overall student demands with reduced resources. Simultaneously, there seems to be a discrepancy between the market needs and the qualifications of new researchers. Additionally, there is a challenge of attracting the young people in the field of scientific research that could have serious repercussions in public awareness about the value and implications of science and technology [8].

Consequently, the knowledge-based economy imposes some challenges for the science system regarding the integration of its knowledge creation role and its corresponding role of knowledge transmission. Many people perceive universities as mainly educational institutions, where the knowledge creation comes as a by-product of their knowledge transmission role. However, as universities manage to overcome their resource limitations that hinder their ability to maintain the adequate ratio between research and education, they might find it difficult to sustain their educational dominance [4].

Furthermore, another pillar of knowledge-based economies is the knowledge transfer, which is guiding the establishment of knowledge distribution networks as a supporting structure for the links between the progress and utilization of knowledge [2]. These national systems of innovation are essential for the national ability to diffuse those innovations and maximize its practical contribution to production processes. In this context, the science system acts as enabling factor for technological knowledge creation and establishment of information exchange culture [8].

Different national economies are characterized by differing degrees of dissemination power required to transfer the knowledge throughout scientific networks, and are partly dependent on incentives and the existence of higher education institutions for disseminating the relevant knowledge. However, as effective knowledge distribution is affected greatly by the capability to adapt it for practical use, establishing related centers is of equal importance. It is not sufficient to invest only in the knowledge production but some incentives need to be established for developing the abilities to diffuse and make the practical use of scientific knowledge [9]. In that regards, the linkages between the science and industry are encouraged to facilitate the associated knowledge diffusion. This has been evident by the provision of government incentives to stimulate the partnerships between universities and industry with the aim of selecting and conducting vital research activities [6]. In that way, new research directions are motivated providing the efficient knowledge transfer along with the required industry skills development.

Previously, when the knowledge production has been derived from public research activities, the patenting was exclusively in the realms of public institutions. However, as the collaboration with the industry developed, patenting issues have become more complex and need to resolve matters of intellectual property rights, licensing, conflicts of interest, equity ownership, etc. Another important consideration in regards to the cooperation among university and industry represents the concern of long term effects originating from this constellation. As the private sector becomes more involved in funding the public research, there is a likelihood of emergence of more specialized scientific research driven by the purely commercial industry needs that could lead, in the long run, to detrimental effects for the university's ability to conduct scientific research [8]. Furthermore, along with these collaborative efforts the traditional role of academic institutions in science creation may be hindered as they try to increase their economic relevance.

Cooperation between research centres and industry tends to favour geographical proximity and an extensive expertise base to establish the supporting infrastructure that would facilitate the relevant knowledge transfer. However, in the presence of ICT these concerns could be easily resolved.

The public part of the science system is facing similar issues. The changes in the structure of supporting research institutes have been initiated to highlight important strategic areas, stimulate the synergies between different disciplines, and encourage the collaboration with the industry that is given the authority to guide basic research activities into relevant directions. As national governments are allocating certain funds for science activities that are believed to bring economic and social benefits, public research institutions may become more pre-

disposed to changes in national priorities which may undermine their basic research mission [4].

In addition to establishing associations with the industry, universities and public research institutes have been frequently expected to make direct contributions to technological problem solving. In the knowledge-based economy this function of the science system has been even more emphasized imposing the challenge of finding the right balance between traditional role in basic research activities and those that generate more immediate returns. In that regards, it has been argued that the science system should be independent of the industry ideas and enable researchers to search for the solutions not necessarily perceived as immediately beneficial to industry [2]. On the contrary, considerable volume of scientific insights has been derived from investigating industry problems. Even though the concept of knowledge intensive economies advances the science system border lines, it is also stimulating a more intense exploring of its fundamental characteristics.

The knowledge-based economy requires the science system to balance between its three important tasks of knowledge production through research, knowledge transmission via education, and knowledge transfer across economic participants and social groups. Nevertheless, there are still some complexities in measuring the magnitude of these functions and developing the accountability norms for the public spending in research activities. Even though there is a general conviction that government funding brings considerable advantages in scientific research, there is a question of associated gains measurement and assessment of adequate financing amounts [4].

As a great deal of scientific knowledge is publicly available, it is difficult to track knowledge use and consequently measure its benefits. Also, the nature of the scientific research outcomes has more of an enabling quality rather than it could be as direct input for generating technological innovations, which further complicates tracking of its positive influences. Another important consideration in measurement issues highlights the potential resource savings resulting from the generation of new scientific knowledge. Therefore, the cost-benefit analysis mainly used for the assessment of public investments would probably degrade the scientific research benefits [5]. Further research needs to be conducted to find the methods for measuring of the overall impact of scientific research activities on key economic indicators. Moreover, evaluation models need to be developed to facilitate effective funding allocations across newly developing and already established areas of scientific research.

The role of national governments and the very nature of the scientific knowledge are causing a great deal of discussions aimed at deeper understanding of the science system role in the knowledge-based economies. The growing role of the science system in the knowledge diffusion and transfer to the industry intended to facilitate the economic growth and enhance the economy competitiveness imposes a challenge for the governments to adapt their national science systems to the requirements of the knowledge-based economies while at the same time not disregarding the fundamental importance of basic research activities.

4. Characteristics of Qatari Economy and the Approach towards the Knowledge-Based Economy

A guided national approach on the way to the foundation of knowledge-based economy would mean that Qatar become more competitive in the global economy where the general directions, previously established, would provide a vital platform for its society's future vision. In this regards, Qatar has to take into consideration the four pillars of the knowledge intensive economy while at the same time accounting for the potential country-specific challenges that may be encountered along the way. Such understanding leads researchers to introduce the fifth pillar into the knowledge-based economy equation to include the social aspect focusing on the gender related issues, social systems, leadership capacities, and entrepreneurship competencies [10]. Nevertheless, the shift towards the knowledge-based economy involves providing the enabling environment to configure the knowledge economy supporting pillars through devising the long term strategies [5]. As a starting point on this journey, Qatar needs to identify and assess its strengths and weaknesses in term of future needs and competencies. The following step would be to provide an effective mechanism for translating the ambitions into the reality by formulating adequate policies and determining required investments that would allow the relevant policy makers to evaluate the progress and compare it to the initially established goals.

The aim of the knowledge-based economy vision development is to gain the support of the wider society and to introduce the required consistency to the initiatives that are already in place and those that are yet to come. Furthermore, the knowledge economy vision needs to be materialized through meticulous plans supporting the economic incentives and institutional structures promoting knowledge-based framework. Additionally, investments need to be made to endorse the interlinked pillars of the knowledge economy, namely education and learning, IT, and innovation that would ensure effective knowledge employment for their establishment. Fol-

lowing this reasoning, Qatar would need to come up with adequate economic incentive framework and institutional system that would enable the efficient use of both national and global knowledge for strengthening the economy competencies while promoting the local entrepreneurial spirit and facilitating the associated social changes. Furthermore, the human capital would need to be sustained by the education quality, lifelong learning opportunities, and availability of jobs while supporting the idea of flexibility, creativity and competence creation [3]. Another important consideration represents a dynamic ICT framework provision that would be able to offer the necessary infrastructure available to all relevant society segments [10]. Likewise, efficient national innovation system would need to be established consisting of public and private sector organizations, science and research institutes, universities, and other relevant stakeholders. These contributors should be able to translate the global knowledge into the local needs to generate new products and services.

Looking at the current economic context of the state of Qatar, it is noted that the high economic growth experienced in the past years is likely to be prolonged. Qatar is considered to be one of the richest countries in the world owing to the country's continued expansion in the LNG industry and the growth of other oil and gas-centred industrial ventures. Even though the reserves of LNG are estimated to last for approximately another 200 years, at the current exploitation pace, with the associated cost of production continuously dropping, Qatar is seeking for ways to shift to a more sustainable knowledge-based economy [10]. Given the current stable economic framework coming from the macroeconomic and political stability and suitable growth rates, Qatar can build on the related strengths in its journey towards the knowledge intensive economy. However, there are still a number of challenges that Qatar needs to address before the transition to a competitive knowledge-based society. Significant investments have already been made to establish a solid foundation for the knowledge-based economy in the fields of education, healthcare, construction, and infrastructure. Nevertheless, these investments still need to be better coordinated to become aligned with the established Qatar National Vision 2030. Also, Qatar needs to decrease its dependency on the external and international know-how with the development of a local more diversified knowledge base.

According to the World Bank Assessment Report in 2005, when compared to other countries from the MENA region, Qatar is considered to have a solid base to make the transition to a knowledge-based economy [11]. The assessment looked at the four pillars of the knowledge intensive economies and the conclusion was that the institutional and informational infrastructures together with the economic incentives are well established while the education and the innovation pillar needed considerable improvements. The quality pertaining to the national human capital and the education structure along with the overall ability of the economy sectors to generate innovations, still need to be considerably improved in order to be a competitive advantage outside the hydrocarbon framework.

Furthermore, institutional infrastructure and the associated government capacity to effectively design and implement relevant policies needs to be put in place before any benefits can be realized from education, ICT and R&D investments. Responsiveness of the relevant institutions, namely labour and financial markets in a knowledge based economy is one of the important considerations [7]. In this regards, the factors that need to be assessed are related to the labor regulations, workforce qualification structure, and government bureaucracy. Additionally, economic incentives should be devised in a way to enable macroeconomic and political stability, offering advantageous incentive regime for Qatar's and international organizations, market competition and regulatory environment encouraging the entrepreneurial spirit [10].

Another important aspect is the Qatar's trade system, as it could be a vital source for creating required technologies, and improving production processes (WTO, 2005). It is capable of enhancing the productivity growth through the technology transfer coming from global markets, as well as through the increased competition which has proven to be an effective efficiency stimulus. Even though energy and telecommunications industries have been traditionally in the realms of the public sector, there have been some trade liberalization initiatives for some parts of the telecommunications sector. This has been driven by the realization that the increase of the private sector role via partial privatization of the national telecommunications sector could lead to increased efficiency. However, despite the slightly increased trend of privatization, there are still certain challenges to be resolved.

The education pillar of the knowledge-based economy is considered to be a vital enabler for its establishment. A well-educated human capital is a fundamental for effective generation, transfer, dissemination, and use of the acquired knowledge. In that respect, quality improvements throughout the entire education system, from early childhood to professional training, is greatly mandatory. The associated national development plans call for the

acquisition of required competencies that would facilitate the national succession planning and enable the gradual substitution of non-Qatari human resources at the higher level of occupational ladder. Due to already established high awareness level for the importance of the education system, there is a public consensus for the need of its improvement and restructuring, which would be able to support the realization of the formulated economic diversification strategy. In this regards, it is important to note that the visible improvements could only be seen in the in the long run [10]. The university system needs to strengthen its links with the industry and labor market and establish partnerships with other prominent universities with the aim to become the internationally renowned player in the field of advanced education and progressive research activities. In turn, this would facilitate the creation of the next generation leaders, researchers and innovators able to successfully enable the transition towards the knowledge-based economy.

Even though there have been improvements in the innovation pillar, significant patents have yet to be recorded for the state of Qatar (Government of Qatar—Qatar Foundation, 2006). Taking into account the critical role it has to play in the knowledge intensive economies, the effective national innovation system has to be developed. The relevant stakeholders in the form of public and private sector organizations, research centers, universities, and others need to be well coordinated on the issues of joint R&D projects, partnerships, cross-patenting, and other important aspects. The important role of innovation promotion and various technology initiatives has been given to Qatar Science and Technology Park (QSTP) that has a mission to conduct sector relevant applied research that could be translated into commercial benefits (Government of Qatar—Qatar Foundation, 2006). Besides the QSTP, there are very few private organizations that have the capacity and incentives to contribute on their own to the innovation momentum. The association between private sector organizations and other key stakeholders is almost non-existent [10]. This is expected as the emphasis on innovation and R&D practices has only been relatively recently introduced to the state of Qatar. Currently, the national innovation strategy is mainly focused on external human capital and technology where the future success of the national innovation system is dependent on the development of internal innovation and research abilities with the associated knowledge transfer (Government of Qatar Planning Council, 2007 [10]). Furthermore, to be able to benefit from the international know-how and new technologies, adequate incentive system needs to be established to encourage the entrepreneurship on the local level. Overall, the innovation system of Qatar would need additional improvements in terms of establishing of the clear long-term vision and corresponding strategy, as well as the strengthening of the collaboration between relevant stakeholders.

Another essential pillar for the knowledge-economy development represents the ICT which is believed to have the significant power to enhance the quality and cost-efficiency of the existing production, generate new education, business, and healthcare opportunities [10]. It is therefore of vital importance that countries use its full potential in all relevant aspects of their economies. Investments in ICT can improve productivity and enhance competitiveness levels across various sectors. In order to establish a sound information framework, it is essential to gain support from relevant stakeholders, namely governmental bodies, private sector, individual users, ICT providers, etc. Additionally, of equal importance is the development of the related human capital that would enable its effective utilization. The key actor in charge of the ICT aspect is the ictQATAR, acting as a supreme council for the ICT in the state of Qatar that regulates the ICT use, drafts legislation, formulates the vision and the strategy [10]. It has also developed the ICT national plan that is comprised of twelve different initiatives and programs to be able to secure the benefits from the associated investments. Overall, even though the national ICT strategy has been devised there is still an important task of setting out the specific goals and time-frames, as well as allocating adequate budgets. The **Figure 1** presents a model of knowledge-based economy using a fuzzy approach.

4.1. The Research Model

The research model as illustrated graphically in the **Figure 1** has been developed in three stages - factors identification stage, fuzzy rules and fuzzy output stage for the initial factors, and the knowledge-based economy measurement stage. The factors are grouped under three sets of factors, where the first set factors are related to government policies approach and characteristics, the second set factors are related to ICT infrastructure characteristics, and the third set factors that are associated to society characteristics. The outputs of initial factors through the set of fuzzy rules are denoted as government policies, knowledge infrastructure, and society norms. The fac-

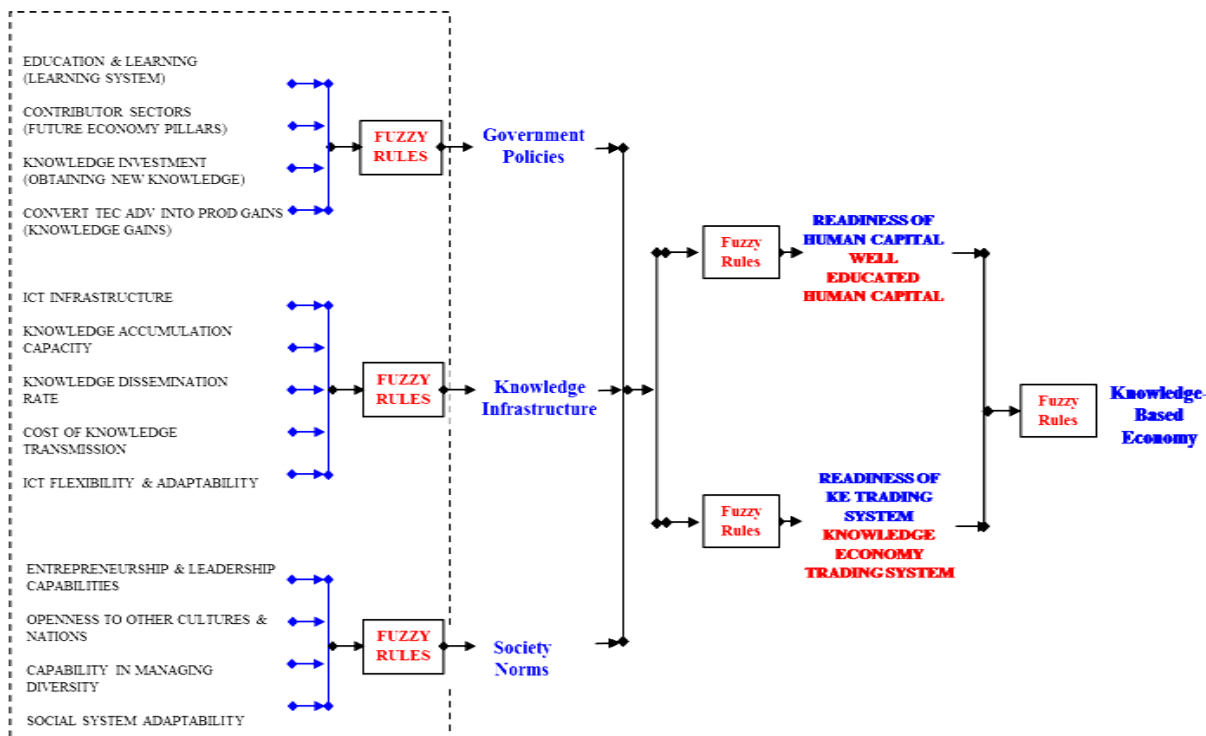

Study's Proposition: Government Policies, Knowledge Infrastructure, and Society Norms have an effect toward Knowledge-Based Economy.

Figure 1. The proposed model of knowledge based economy using fuzzy approach.

tor “government policies” is the output of the factors related to government regulations. The factor “knowledge infrastructure” is the output of factors related to ICT infrastructure characteristics. The factor “society norms” is the output of factors related to the characteristics of the society. The combination of government policies, ICT infrastructure, and society norms through a set of fuzzy rules generates an output to measure knowledge based economy level through two sets, namely readiness of human capital and readiness of knowledge economy trading system. The subsequent sections explain each factor in greater detail.

- **Education & Learning (Learning System)**

According to International Standard Classification of Education (ISCED), education system is defined as “organized and sustained communication designed to bring about learning”. “Communication” in this context requires a relation between two or more persons involving the transfer of information (messages, ideas, knowledge, strategies, etc.). “Organized” refers to planning in a pattern or sequence with established aims or curricula and which involves an educational agency that organizes the learning situation and/or teachers who are employed (including unpaid volunteers) to consciously organize the communication. “Sustained” means that the learning experience has the elements of duration and continuity. “Learning” is taken as any change in behavior, information, knowledge, understanding, attitudes, skills, or capabilities which can be retained and cannot be ascribed to physical growth or to the development of inherited behavior patterns [12]. Moreover, when considering the definition of the education and learning system it is important to allow for an understanding of education as a complex system embedded in a political, cultural and economic context [13].

- **Contributor Sectors (Future Economy Pillars)**

It refers to the economic environment and the effective regulatory economic policies, and institutional framework to allow efficient mobilization and allocation of resources that are aligned with future economic needs as per state vision and its future economic planning.

- **Knowledge Investment (Obtaining New Knowledge)**

According to OECD Glossary of Statistical Terms, investment in knowledge is defined as the sum of expenditures in research and development (R&D), on total higher education (public and private) and on software. Investment in this context has a broader connotation than its usual meaning in economic statistics. It includes current expenditures, such as on education and R&D, as well as capital outlays, such as purchases of software and

construction of school buildings [14].

- **Convert Tec Adv into Prod Gains (Knowledge Gains)**

It refers to the ability to convert technology advancement into productivity gains. Usually technology is incorporated directly into the production function whereas the output is produced using the factors of labor, capital, and the present state of technology. Therefore, according to the Cobb-Douglas production function—technology directly increases the productivity of labor, and indirectly that of capital, in the production of output [15].

- **ICT Infrastructure**

The previous few decades have been characterized by the emergence of a vast range of new communication capabilities attributable to ICT infrastructure advancements. Information and Communication Technologies refer to technologies that offer access to information through telecommunications. The data of ICT infrastructure consists of five components: 1) hardware, 2) software, 3) brainware, 4) network, and 5) dataware [16]. A high-quality ICT infrastructure is often believed to be the most critical factor for instituting a knowledge-based economy.

- **Knowledge Accumulation Capacity**

Cohen & Levithal (1990) have originally defined the concept of the absorptive capacity as the capability to identify the value of new information, assimilate it, and use it for economic gains. According to their theory, absorptive capacity is influenced by prior related knowledge and background diversity. Thus, the R&D investments have been seen as central to their model of absorptive capacity development which is seen as rather cumulative. Following this reasoning, the efforts made to develop the absorptive capacity in one period are believed to make it easier to accumulate it in the subsequent one [17]. Absorptive capacity can be defined as “the appropriate supply of human capital and technological capability to be able to generate new technologies and consequently use productive resources efficiently” [18]. Consequently, this is estimated to translate into productivity growth on organizational as well as national economies level.

- **Knowledge Dissemination Rate**

“Economic growth concerns not just the acquisition and development of knowledge through innovation and learning, but also the diffusion and efficient utilization of this knowledge” [18]. Knowledge dissemination rate refers to the speed and extent of an active approach to spreading knowledge to the target audience through determined channels via planned strategies [19]. Given the shorter cycles of innovation and production along with the “increased speed in knowledge dissemination and turnover, nowadays the new information replaces older information at a much faster rate” [20].

- **Cost of Knowledge Transmission**

In regards to the costs of knowledge transfer, it has been found that higher costs are associated to greater levels of knowledge tacitness [21]. Because knowledge is harder to disseminate than information due knowledge hierarchical dependencies, the cost of its transmission is higher compared to the cost of information transfer. However, knowledge could be “codified and reduced to information can now be transmitted over long distance with very limited costs” [4]. The share of codified vs. tacit knowledge has been increased due to the digital revolution. “Electronic networks now connect a vast array of public and private information sources, including digitized reference volumes, books, scientific journals, libraries of working papers, images, video clips, sound and voice recordings, graphical displays as well as electronic mail” [4]. Due to its codification, knowledge is acquiring the characteristics of a commodity whereby market transactions can occur.

- **ICT Flexibility and Adaptability**

Every organization that relies on ICT has to formalize its implementation approach and to correspondingly establish the organizational design that supports the use and implementation of ICT systems and applications [22]. Despite that, most of organizations do not have clear long-term strategies to address the issues of flexibility and adaptability in responding to changing overall conditions, which can result in complicated ICT infrastructures that are difficult and costly to manage effectively. For that reason, it is important to understand that ICT infrastructures are more than just ICT systems and applications, and their flexibility represents a foundation for effectively responding to current and future organizational needs. Accordingly, it should be closely linked to organizational strategies for the purpose of generating greater economic value [22].

- **Entrepreneurship & Leadership Capabilities**

The entrepreneurship capabilities usually refer to entrepreneur’s human and social capital. In this context, in addition to their capabilities, skilled entrepreneurs are those that have the “access to other capabilities within the entrepreneurial infrastructure” [23]. Entrepreneurial capability is just one of the six decisive determinants that

affect the overall entrepreneurship performance (access to research and development & technology access to capital, market conditions, regulative environment and culture). Furthermore, according to OECD/EUROSTAT (2012) framework there are four identified factors that influence entrepreneurship capabilities, namely: training and experience of entrepreneurs (training can take many forms and is mostly offered as part of a country's public entrepreneurship support system [24]. Skills can be acquired through experience, as well. However, learning through failure is not much encouraged due to legislative barriers referring to bankruptcy legislation or excessive time and costs associated with the business restarting), business education (traditional business education, acquired through formal education system is essential for both establishing and running a successful business. It is important to note that there are considerable differences in the magnitude of available business education among different countries and regions), entrepreneurship education and skills (in order to support entrepreneurial capabilities through education, activities that go beyond traditional teaching methods should be established. This education should be aimed at strengthening the skills required to succeed as an entrepreneur and forming the entrepreneurial mindset. When it comes to leadership, Ancona *et al.* (2005) have developed a framework that integrates previous leadership theories while observing it as the capacity of both individuals and groups [25]. They identified the four essential capabilities of effective leadership, which has shifted to "change and cultivate" model where the following 4 complementary capabilities make all the difference: sense-making (understanding the overall surrounding context), relating (ability to develop and maintain the relationships), visioning (constructing a compelling vision of the future that would motivate people to change their existing views), and inventing (creating new ways and mobilizing group commitment towards vision realization while implementing innovative processes and structures that would facilitate the vision accomplishment).

- ***Openness to Other Cultures and Nations***

Openness to other cultures and nations is often referred to as the "Global Mindset". Gupta *et al.* (2008) describes the global mindset as a fusion between the awareness and openness to various cultural diversities along with the cognitive capacity to synthesize through those diversities [26]. In that regards, Rhinesmith (1992) attempts to define the underlying concept of a mindset with the individuals overall predisposition to understand the world in a certain manner that provides clarifications for better understanding of its surroundings, and simultaneously offering behavior guidelines [27]. Thus, the mindset acts like a filter that shapes ones perception of the world. It denotes a proactive orientation to the world that enables one to see the things others are not able to see. If we were to add the "global" connotation to a mindset concept, it would just expand the definition to a broader perspective including a more holistic response to the world that would further endow one with the ability to translate these inferences into profitable actions accounting for the unforeseen trends and opportunities.

- ***Capability in Managing Diversity***

Diversity in this context refers to gender, age, cultural background, ethnicity, religious belief, etc. In general, it encompasses all the ways in which people can differ from each other, for instance their level of education, life and work experiences, their socio-economic background, and personality traits. The concept of diversity indicates recognizing the added value of those individual differences and accordingly managing them in order to translate them to tangible benefits. Managing diversity effectively suggests establishing an "environment that values and utilizes the contributions of people with different backgrounds, experiences and perspectives" [28].

- ***Social System Adaptability***

The contemporary academic research on the adaptive capacity of social systems has focused on exploring the characteristics of society for the purpose of enhancing its capacity to effectively manage and institutionalize social changes [29]. It is based on the view that social issues are complex in their nature and frequently multi-dimensional. Consequently, the challenge is to enhance the overall social system ability to be able to respond to the on-going changes, while maintaining the system flexibility to manage the unforeseen ones. In that sense, the adaptive capacity of social systems represents a fundamental function for its sustainable development, which has become a normative aspect of good governance in contemporary societies [30].

4.2. The Methodology

4.2.1. The Dimensions Measurement

This study adopts fuzzy approach methodology in analyzing the research problem. This method is a little different from the conventional method in studying management phenomena. The fuzzy approach seeks to quantify and measure relationship of various attributes not measuring the attributes itself. It is to some extent similar to the methodology adopted within marketing behavior studies that seek to examine the relationship between the

factors of the studies by discriminant analysis and categorizing the factors of the research in groups and categories to quantify the relationship between those factors and their pattern effects.

The fuzzy rule based systems have been shown to be accurate not only in real-life applications such as control, modelling and classification, but also on the interpretability of the factors affecting the phenomena under study (Casillas *et al.* 2003). In general, a large numbers of fuzzy rules are pulled out in a heuristic method using rule evaluation criteria. It is very difficult for human to understand and capture thousands of fuzzy rules when analyzing a phenomenon under study. Therefore, rules should be significantly decreased to present an understandable knowledge to the readers and practitioners.

In many real world applications, fuzzy systems, which use linguistics rules as a basic element to model the phenomena under the study, are quite appropriate to describe the behaviour of complex problems that are difficult to model mathematically. Fuzzy researchers utilize fuzzy sets to represent non-statistical behaviour, uncertainty, and approximate reasoning to be applied on real life data. In most of the cases studied using this approach, the fuzzy rules with few input variables are developed by the experts and decision makers who are well versed with the problem. The advantage of generalizing rules is that they can cover several input situation, and therefore fewer rules are necessary to design the fuzzy rule base. The possible number of fuzzy rules for a given problem rises exponentially when the number of input variables increases which makes the definition and generation of the complete rule set to assess the system performance very difficult. In several cases, the system performance is improved by the amendment of membership functions and selecting the suitable fuzzification and defuzzification approach. To model the performance measurement and evaluation system of knowledge based economy readiness, the basic fuzzy rules should be generated from experts and practitioners in the field of knowledge based economy by a structured questionnaire.

The questionnaire is formulated into three categories. A set of fuzzy rules capturing the factor of government regulations as presented by government in their policies and approaches, which are based on a set of four antecedents; learning system, future economy pillars, obtaining new knowledge, and knowledge gains varied on three levels of low, medium and high. A second set of fuzzy rules capturing the factors of ICT infrastructure characteristics based on a set of five antecedents; ICT Infrastructure, Knowledge Accumulation Capacity, Knowledge Dissemination Rate, Cost of Knowledge Transmission, and ICT Flexibility and Adaptability. The third set of fuzzy rules capturing the factor of social norms is based on a set of four antecedents, namely Entrepreneurship and Leadership Capabilities, Openness to other Cultures and Nations, Capability in Managing Diversity, and Social System Adaptability.

4.2.2. Questionnaire Design

This study adopted expert-driven way to develop the fuzzy system to evaluate the knowledge-based economy level. Hence, a set of questions originally should be developed to gather knowledge and information from experts who have been dealing with the subject of knowledge-based economy. The goal of this step is the definition of a rule base, and the collection of the fuzzy “if-then” rules, which specify driving factors of knowledge-based economy

The three predicate modifiers, which are low, medium and high in describing factors involved in knowledge-based economy, have been used. Bearing in mind the need to minimize complexity without losing variables sensitivity, three linguistic levels—low, medium and high, were implemented for every variable of the research model. The three linguistics levels of low, medium and high were used for the following reasons:

- 1) They are the predicate modifiers commonly used in describing the impact of factors involved in any new phenomena.
- 2) To define a rule base in which the effects of all the inputs were distinguishable and non-confounded.
- 3) To obtain acceptable effects of the variation in the variables.
- 4) To be able to simulate the synergetic effect between the factors within the rule base.

4.2.3. The Genetic Algorithm

1) Rules Representation

While designing a fuzzy expert system using Genetic Algorithm (GA), the first important step is the adaptation of the coding system in representing the problem under the study from the fuzzy rules into the chromosome. The fuzzy system would not be well defined if the fuzzy rule base and the membership functions related with each fuzzy set of variable are not fully specified. In this research, three categories of variables were identified,

where the first variable have six fuzzy set, and the second and third variable have five fuzzy set, were considered to evaluate the deal closure performance. The evaluation is based on five steps. The first step assesses government policies, the second assesses knowledge infrastructure, the third assesses society norms, the fourth readiness of human capital and readiness of knowledge economy trading system, and lastly the fifth evaluates the level of readiness of knowledge based economy. The membership functions correspond to the fuzzy sets of input variables, measured as low, medium and high. In this study, each input/output in the fuzzy set is represented by four integers 1 for low, 2 for medium, 3 for high, and use of value 0 to represent the absence of the factor. For example, a rule from a case of government policies that is evaluated by four factors in which the input is medium, low, high, high, and the output is medium; then the rule can be encoded as 2 1 3 3 2.

2) The Membership Function

In many cases, performance is found to be improved by changing the membership functions and selecting suitable fuzzification and defuzzification methods. Defuzzification is the translation of fuzzy data to precise data. It includes approaches such as max-membership principle, centroid method, weighted average method, center of sums and so on [13]. This study adapts weighted average method as the defuzzification approach of the fuzzy output data, whereas for the input linguistic variable, the simple average method was adopted as the defuzzification approach. The output membership function is given by the algebraic expression below:

Output membership function is taken as the equation $(x_1w_1 + x_2w_2 \cdots + x_nw_n)/(w_1 + w_2 \cdots + w_n)$

$$\text{Output Membership Function} = \frac{\sum_{i=1}^n (x_i w_i)}{\sum_{i=1}^n w_i} \quad (1)$$

3) The Fitness Function

The fitness function evaluates the performance of the rule base as represented by integer strings. Since the objective in negotiation analysis is to evaluate the deal closure performance, the absolute difference error is taken to evaluate the fitness of the chromosomes

$$E = (1/N) \sum |O_i - e_i| \quad (2)$$

Whereas N is the number of evolved fuzzy rules and e_i is the expected outputs obtained by assigning priorities to the input variable. The chromosomes with higher fitness value are carried to the next generation.

$$\text{Chromosome Fitness Value} = 1/1 + E \quad (3)$$

4) The Crossover Operator

Crossover is the process by which two parent strings recombine to produce two new offspring strings. It is usually applied to selected pairs of parents with a probability equal to a given crossover rate. In this case, a random point is selected and the column behind this point is exchanged as whole.

5) Mutation

Mutation is the process of change that occurs in chromosomes. It is a random alert of few composition of a string to produce a new offspring, instead of recombining two strings. In this research the mutation used is increased or decreased by replacing the integer with another in the range of [4] [5] excluding the present value of the element. The integers of the string are independently mutated. The mutation of the element does not influence the probability of mutation of another element.

6) The Algorithm

In this research, the process works as below:

- a) The obtained population through the questionnaire is regrouped, based on the outcome level high, medium and low.
- b) Applying the simple average method in representing the membership values of the input linguistic variables.
- c) Applying weighted average method as the composition rule for the fuzzy output data, Equation (1).
- d) Calculate the fitness $f(x)$ of each chromosome x in the sub-population, Equation (3).
- e) Repeat the following steps until n offspring have been created.
- f) Select a pair of parent chromosomes from current populations, the probability of selection being an increasing function of fitness.

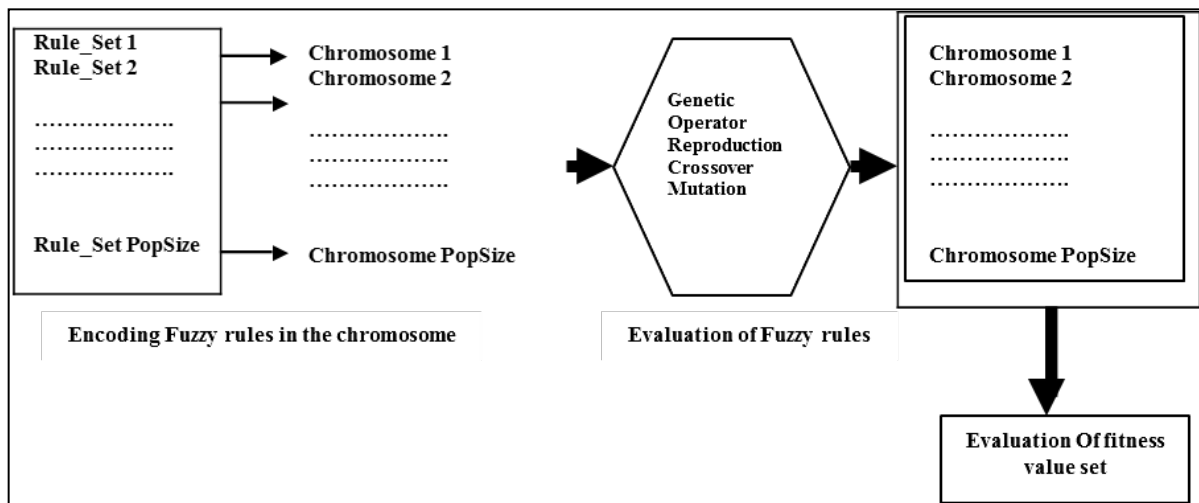

Figure 2. System flowcharts for illustrating the evolution of optimum fuzzy rule base.

- g) With crossover rate, cross over the pair at a randomly chosen point to form two offsprings.
- h) Mutate the two offsprings at each locus with a known mutation rate, and replace the new chromosomes in the new population. If n is odd, one new population member can be discarded at random.
- i) Replace the current population with the new population.
- j) Go to the step 2.
- k) Keep the process from step 1 to step 8 for n times until you get satisfied with the results and make the decision based on the generated solutions.

The **Figure 2** summarizes the above steps.

5. Conclusion

The main focus of this paper was to propose the most effective multidimensional model that would help evaluate the factors affecting the knowledge-based economy transition. The utilization of the fuzzy approach has been proposed due to its ability to accurately quantify the relationships between factors under study in real-life applications. It is also considered to be particularly accommodating in facilitating the decision-making process by significantly decreasing the number of rules that need to be taken into consideration in evaluating complex multidimensional models. Therefore, the mentioned approach by using the expert-driven fuzzy system has been proposed to assess the knowledge-based economy readiness level whereas, the presented model and methodology could significantly help decision-makers in understanding and identifying the factors affecting the transition towards a knowledge-based economy in a non-static, fast-changing world. The authors invite researchers to apply the model and use the described approach and the explained steps in different economies to evaluate the relationships of the factors and their significance.

References

- [1] Mansfield, E. (1991) Academic Research and Industrial Innovation. *Research Policy*, **20**.
<http://www.congovision.com/science/NGITLiteratureReview2.pdf>
[http://dx.doi.org/10.1016/0048-7333\(91\)90080-A](http://dx.doi.org/10.1016/0048-7333(91)90080-A)
- [2] David, P. and Foray, D. (1995) Accessing and Expanding the Science and Technology Knowledge Base. *STI Review*, No. 16, OECD, Paris.
- [3] Baldwin, J., Diverty, B. and Johnson, J. (1995) Success, Innovation, Technology and Human Resource Strategies—An Interactive System. *Conference on “The Effects of Technology and Innovation on Firm Performance and Employment”*, Washington DC, 1-2 May 1995.
- [4] Organization for Economic Co-Operation and Development (1996) *The Knowledge-Based Economy*.
- [5] Lundvall, B. and Johnson, B. (1994) The Learning Economy. *Journal of Industry Studies*, **1**, 23-42.
<http://dx.doi.org/10.1080/13662719400000002>

- [6] European Innovation Monitoring System (EIMS) (1994) Public Policies to Support Tacit Knowledge Transfer. *Proceedings of SPRINT/EIMS Policy Workshop*, May 1993.
- [7] Lauritzen, F. (1996) Technology, Education and Employment. In: *Employment and Growth in the Knowledge-Based Economy, Proceedings of the Conference on "Employment and Growth in the Knowledge-Based Economy"*, Copenhagen, November 1994.
- [8] Gibbons, M., Limoge, C., Nowotny, H., Schwartzman, S., Scott, P. and Trow, M. (1994) *The New Production of Knowledge: The Dynamics of Science and Research in Contemporary Societies*. Sage Publications, London.
- [9] Powel, W.W. and Snellman, K. (2004) The Knowledge Economy. *Annual Review of Sociology*, **30**, 199-220. <http://www.oecd.org/science/sci-tech/1913021.pdf>
<http://dx.doi.org/10.1146/annurev.soc.29.010202.100037>
- [10] Government of Qatar Planning Council (2007) Turning Qatar into a Competitive Knowledge-Based Economy.
- [11] Chen, D.H. and Dahlman, C.J. (2005) The Knowledge Economy. The KAM Methodology and World Bank Operations. *World Bank Institute Working Paper* No. 37256, Washington DC.
- [12] UIS, OECD and EUROSTAT (2002) Data Collection on Education Systems: Definitions, Explanations and Instructions. Organization for Economic Co-Operation and Development, Paris.
- [13] UNICEF (2000) Defining Quality in Education. *UNICEF at the Meeting of the International Working Group on Education Florence*, Italy, June 2000.
- [14] OECD (2005) Science and Technology Statistics. OECD Factbook: 2005. Organization for Economic Co-Operation and Development, Paris, 118.
- [15] Pakko, M.R. (2002) Investment-Specific Technology Growth: Concepts and Recent Estimates. *Federal Reserve Bank of St. Louis Review*, **84**, 37-48.
- [16] Elmunsyah, H. (2012) A Study of ICT Infrastructure and Access to Educational Information in the Outskirts of Malang. *Acta Didactica Napocensia*, **5**, 41.
- [17] Cohen, W. and Levinthal, D. (1990) Absorptive Capacity: A New Perspective on Learning and Innovation. *Administrative Science Quarterly*, **35**, 128-152. <http://dx.doi.org/10.2307/2393553>
- [18] Narula, R. (2004) Understanding Absorptive Capacities in an "Innovation Systems" Context: Consequences for Economic and Employment Growth, Research Memoranda 004. MERIT, Maastricht Economic Research Institute on Innovation and Technology, Maastricht.
- [19] Brownson, R. (2012) *Dissemination and Implementation Research in Health: Translating Science to Practice*. Oxford University Press, Oxford. <http://dx.doi.org/10.1093/acprof:oso/9780199751877.001.0001>
- [20] Nadin, M. (2002) Education in the Digital Age: Knowledge Dissemination in Upheaval. In: Deubel, V. and Kiefer, K.H., Eds., *Visualization and Digitization in Knowledge Dissemination*, Aisthesis Verlag, Bielefeld.
- [21] Bae, J. and Koo, J. (2008) Information Loss, Knowledge Transfer Cost and the Value of Social Relations. *Strategic Organization*, **6**, 227-258. <http://dx.doi.org/10.1177/1476127008093518>
- [22] Makatiani, W. (2012) How to Build Adaptable ICT Structure. <http://www.businessdailyafrica.com/Opinion-and-Analysis/How-to-build-adaptable-ICT-structure/-/539548/1497456/-/10y1dndz/-/index.html>
- [23] Lee, C.M., Miller, W., Hancock, M. and Rowen, H. (2000) *The Silicon Valley Edge. A Habitat for Innovation and Entrepreneurship*. Stanford University Press, Palo Alto.
- [24] OECD/EUROSTAT (2012) http://epp.eurostat.ec.europa.eu/cache/ITY_OFFPUB/KS-31-12-758/EN/KS-31-12-758-EN.PDF
- [25] Ancona, D. (2005) Leadership in an Age of Uncertainty, MIT Leadership Center: Research Brief. http://ebusiness.mit.edu/research/Briefs/Ancona_Leadership_Final_VI.pdf
- [26] Gupta, V., Govindarajan, V. and Wang, H. (2008) *The Quest for Global Dominance: Transforming Global Presence into Global Competitive Advantage*. 2nd Edition, Jossey-Bass, Washington DC.
- [27] Rhinesmith, S.H. (1992) Global Mindsets for Global Managers. *Training and Development*, **46**, 63-69.
- [28] Public Service and Merit Protection Commission (PSMPC) (2001) Working Together. <http://www.apsc.gov.au/publications-and-media/archived-publications/publications-archive/workplace-diversity-guidelines>
- [29] Ludi, E., Jones, L. and Levine, S. (2012) Changing Focus? How to Take Adaptive Capacity Seriously. Overseas Development Institute, Briefing Paper.
- [30] Jordan, A. (2008) The Governance of Sustainable Development: Taking Stock and Looking Forwards. *Environment and Planning C: Government and Policy*, **26**, 17-33. <http://dx.doi.org/10.1068/cav6>