

# PID Parameters Optimization Using Genetic Algorithm Technique for Electrohydraulic Servo Control System

Ayman A. Aly

*Mechatronics Section, Faculty of Engineering, Assiut University, Assiut, Egypt*  
*Mechatronics Section, Faculty of Engineering, Taif University, Taif, Saudi Arabia*  
*E-mail: ayman\_aly@yahoo.com*

*Received January 16, 2011; revised March 21, 2011; accepted March 26, 2011*

## Abstract

Electrohydraulic servosystem have been used in industry in a wide number of applications. Its dynamics are highly nonlinear and also have large extent of model uncertainties and external disturbances. In order to increase the reliability, controllability and utilizing the superior speed of response achievable from electrohydraulic systems, further research is required to develop a control software has the ability of overcoming the problems of system nonlinearities. In This paper, a Proportional Integral Derivative (PID) controller is designed and attached to electrohydraulic servo actuator system to control its angular position. The PID parameters are optimized by the Genetic Algorithm (GA). The controller is verified on the state space model of servovalve attached to a rotary actuator by SIMULINK program. The appropriate specifications of the GA for the rotary position control of an actuator system are presented. It is found that the optimal values of the feedback gains can be obtained within 10 generations, which corresponds to about 200 experiments. A new fitness function was implemented to optimize the feedback gains and its efficiency was verified for control such nonlinear servosystem.

**Keywords:** Optimal Control, PID, GA, Electrohydraulic, Servosystem

## 1. Introduction

Electrohydraulic servosystems are widely used in many industrial applications because of their high power-to-weight ratio, high stiffness, and high payload capability, and at the same time, achieve fast responses and high degree of both accuracy and performance [1,2]. However, the dynamic behavior of these systems is highly nonlinear due to phenomena such as nonlinear servovalve flow-pressure characteristics, variations in trapped fluid volumes and associated stiffness, which, in turn, cause difficulties in the control of such systems.

Control techniques used to compensate the nonlinear behavior of hydraulic systems include adaptive control, sliding mode control and feedback linearization. Adaptive control techniques have been proposed by researchers assuming linearized system models. These controllers have the ability to cope with small changes in system parameters such as valve flow coefficients, the fluid bulk modulus, and variable loading. However, there is no guarantee that the linear adaptive controllers will remain globally stable in the presence of large changes in the

system parameters, as was demonstrated experimentally by Bobrow and Lum [3]. Variations of sliding mode controllers have also been developed for electrohydraulic servosystems. These controllers are robust to large parameter variations, but the nearly discontinuous control signal excites unmodeled system dynamics and degrades system performance. This can be reduced by smoothing the control discontinuity in a small boundary layer bordering the sliding manifold as introduced in simulations [4,5]. The nonlinear nature of the system behavior resulting from valve flow characteristics and actuator nonlinearities have been taken into account in application of the feedback linearization technique [6]. The main drawback of the resulting linearizable control law is that it relies on exact cancellation of the nonlinear terms.

A. Aly [7] presented a nonlinear mathematical model which allows studying and analysis of the dynamic characteristic of an electrohydraulic position control servo. Response for the angular displacement of motor shaft due to large amplitude step input were obtained by applying velocity feedback control strategy. To improve the dynamics response characteristics and based on the

mathematical model driven, the implementation of self tuning fuzzy logic controller (STFLC) technique was investigated in [8] for positioning the servo motor system as a nonlinear plant. Feasibility and robustness of such application was assured. However, it is still extremely difficult to establish a systematic standard design method for fuzzy logic control system like PID controller which is forward linear differential equation.

Over the past a few years, many different techniques have been developed to acquire the optimum control parameters for PID controllers. The academic control community has developed many new techniques for tuning PID controllers. They have not been slow in seeking to exploit the emerging methods based on the principles of evolution. A GA is one such direct search optimization technique which is based on the mechanics of natural genetics. An advantage of the GA for autotuning is that it does not need gradient information and therefore can operate to minimize naturally defined cost functions without complex mathematical operations, [9].

This article describes the application of GA Technique based on new fitness function to optimally tune the three terms of the classical PID controller to regulate a valve controlled hydraulic servosystem as a nonlinear process.

The paper has been organized as follows: Section 2 describes the system dynamic model. Section 3 reviews the PID tuning methods and introduces the new techniques for PID tuning method. Section 4 presents a simulation of the system with GPID controller. Finally, a conclusion of the proposed GPID technique is presented in Section 5.

## 2. System State Space Dynamic Model

The hydraulic position control system consists of a pres-

sure compensated vane pump, a two-stage servovalve (Moog Model 761 [10]) a servoamplifier, and a fixed displacement hydraulic motor with an inertial load attached to the motor shaft, **Figure 1**. A shaft encoder is attached to the motor shaft for position measurement. This type of hydraulic system is typically applied to mixer drives, centrifuge drives and machine tool drives where accurate control with fast response times is required and large changes in load can be expected.

The control signal is the voltage to the servoamplifier, the resulting servoamplifier current actuating the servovalve. The dynamic model is developed under the following assumptions:

- 1) The supply pressure is constant.
- 2) Servovalve orifices are symmetrical.
- 3) Valve flow is modeled by turbulent flow through sharp-edged orifices.
- 4) Motor external leakage is negligible.

The nonlinear dynamic equations describing the system may then be written in a compact state-space form, the control input being the voltage to the servoamplifier. Definitions of the state variables and inputs of the system are given below:

States:

$$[x_1 \ x_2 \ x_3 \ x_4] = [\theta(t) \ \dot{\theta}(t) \ P_L(t) \ \dot{P}_L(t)] \quad (1)$$

Inputs:

$$[u_1 \ u_2] = [V_i(t) \ P_s] \quad (2)$$

Applying the states definition to the system, after manipulation, results in the state variable model as follows:

$$\dot{x}_1 = x_2, \quad \dot{x}_2 = -\frac{B}{J}x_2 + \frac{V_m}{J}x_3 - \frac{T_c}{J}\text{sgn } x_2, \quad \dot{x}_3 = x_4$$

and

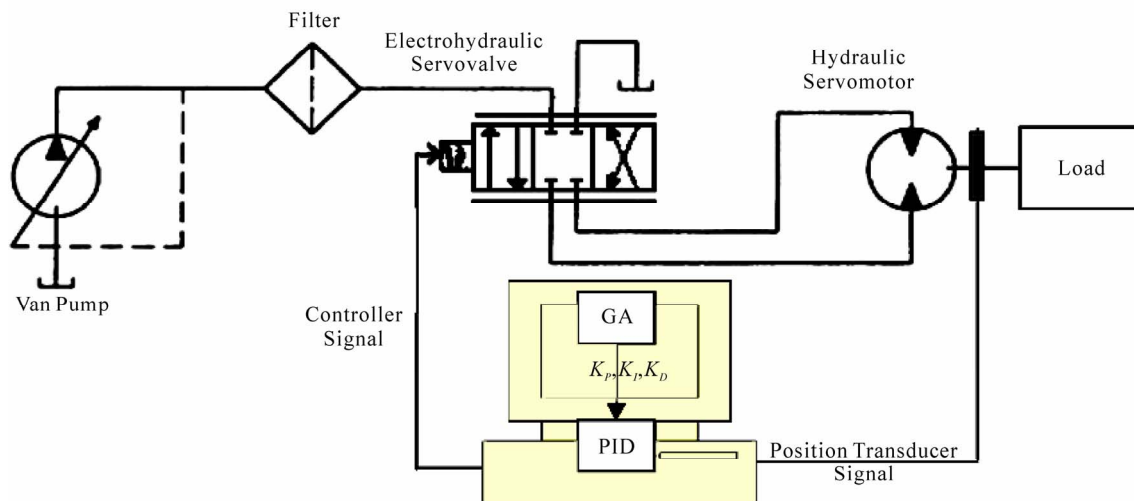

**Figure 1. Electrohydraulic rotary position servosystem.**

$$\begin{aligned}
\dot{x}_4 = & -x_1 \left[ \frac{4K_h K_x K_a k_\theta k_s}{\tau V_c n} \operatorname{sgn} \left\{ 1 - (\operatorname{sgn} V_x) \frac{x_3}{u_2} \right\} \sqrt{\left| 1 - (\operatorname{sgn} V_x) \frac{x_3}{u_2} \right|} \right] + x_2 \left[ \frac{4K_h}{\tau V_c} \left( \frac{\tau V_m B}{J} - V_m \right) \right] \\
& - x_3 \left[ \frac{4K_h V_m^2}{J V_c} + \frac{4K_h L_e}{\tau V_c} \right] - x_4 \left[ \frac{1}{\tau} + \frac{4K_h L_e}{V_c} \right] + \frac{4K_h V_m}{J V_c} T_c \operatorname{sgn} x_2 \\
& + \left( \frac{4K_h}{\tau V_c} \right) K_x K_a u_1 \operatorname{sgn} \left\{ 1 - (\operatorname{sgn} V_x) \frac{x_3}{u_2} \right\} \sqrt{\left| 1 - (\operatorname{sgn} V_x) \frac{x_3}{u_2} \right|}
\end{aligned} \tag{3}$$

The state variables model represented by (1-3) is of the nonlinear form:

$$x = f[x, u] \tag{4}$$

The initial conditions of the state variables are given by:

$$[x_1(0) \ x_2(0) \ x_3(0) \ x_4(0)] = [0 \ 0 \ 0 \ 0] \tag{5}$$

More details in the system dynamics model and its parameters are given in **Appendix A**.

The objective of the controller is to keep the angular position of the motor following a desired trajectory as precisely as possible.

### 3. PID Controller Tuning

The popularity of PID controllers in industry stems from their applicability and due to their functional simplicity and reliability performance in a wide variety of operating scenarios. Moreover, there is a wide conceptual understanding of the effect of the three terms involved amongst non-specialist plant operators. In general, the synthesis of PID can be described by,

$$u(t) = K_p e(t) + K_I \int_0^t e(t) dt + K_D \frac{de(t)}{dt} \tag{6}$$

where  $e(t)$  is the error,  $u(t)$  the controller output, and  $K_p$ ,  $K_I$ , and  $K_D$  are the proportional, Integral and derivative gains.

There is a wealth of literature on PID tuning for scalar systems, [11-13]. Good reviews of tuning PID methods are given in Tan *et al.* [14] and Cominos and Munro [15]. Among these methods are the well known Ziegler and Nichols [16] Cohen and Coon [17]. Many researchers have attempted to use advanced control techniques such as optimal control to restrict the structure of these controllers to PID type.

Recently, Hao *et al.* [18] have illustrated a simple approach for PID control of select the parameters of single neuron adaptive PID controller designing. Using adaptive PID controller based on neuron optimization, they show that the genetic optimize algorithm can get better control characteristics.

### 3.1. GPID Tuning Strategy

Genetic programming (Koza, *et al.* [19]; Koza, *et al.* [20] and Reeves [21]) is an automated method for solving problems. Specifically, genetic programming progressively breeds a population of computer programs over a series of generations. Genetic programming is a probabilistic algorithm that searches the space of compositions of the available functions and terminals under the guidance of a fitness measure. Genetic programming starts with a primordial ooze of thousands of randomly created computer programs and uses the Darwinian principle of natural selection, recombination (crossover), mutation, gene duplication, gene deletion, and certain mechanisms of developmental biology to breed an improved population over a series of many generations.

Genetic programming breeds computer programs to solve problems by executing the following three steps:

1) Generate an initial population of compositions of the functions and terminals of the problem.

2) Iteratively perform the following substeps (referred to herein as a generation) on the population of programs until the termination criterion has been satisfied:

a) Execute each program in the population and assign a fitness value using the fitness measure.

b) Create a new population of programs by applying the following operations. The operations are applied to program selected from the population with a probability based on fitness (with reselection allowed).

- **Reproduction:** Copy the selected program to the new population. The reproduction process can be subdivided into two subprocesses: Fitness Evaluation and Selection. The fitness function is what drives the evolutionary process and its purpose is to determine how well a string (individual) solves the problem, allowing for the assessment of the relative performance of each population member.
- **Crossover:** Create a new offspring program for the new population by recombining randomly chosen parts of two selected programs. Reproduction may proceed in three steps as follows: 1) two newly reproduced strings are randomly selected from a Mating Pool; 2) a number of crossover positions along

each string are uniformly selected at random and 3) two new strings are created and copied to the next generation by swapping string characters between the crossover positions defined before.

- Mutation: Create one new offspring program for the new population by randomly mutating a randomly chosen part of the selected program.
- Architecture-altering operations: Select an architecture-altering operation from the available repertoire of such operations and create one new offspring program for the new population by applying the selected architecture-altering operation to the selected program.

3) Designate the individual program that is identified by result designation (e.g., the best-so far individual) as the result of the run of genetic programming. This result may be a solution (or an approximate solution) to the problem. The specification of the designed GA technique is shown in **Table 1**.

**Figure 2** shows the flowchart of the parameter optimizing procedure using GA. For details of genetic operators and each block in the flowchart, one may consult literature [22].

**3.2. Fitness Measure**

The fitness measure is a mathematical implementation of the problem’s high level requirements. That is, our fitness measure attempts to optimize for the integral of the time absolute error (ITAE) for a step input and also to optimize for maximum sensitivity.

**Figure 3** shows the block diagram for adjusting the PID parameters via GA on line with the SIMULINK model. To begin with, the GA should be provided with a population of PID sets. The initial population for choosing PID parameters are derived from the trial-and-error

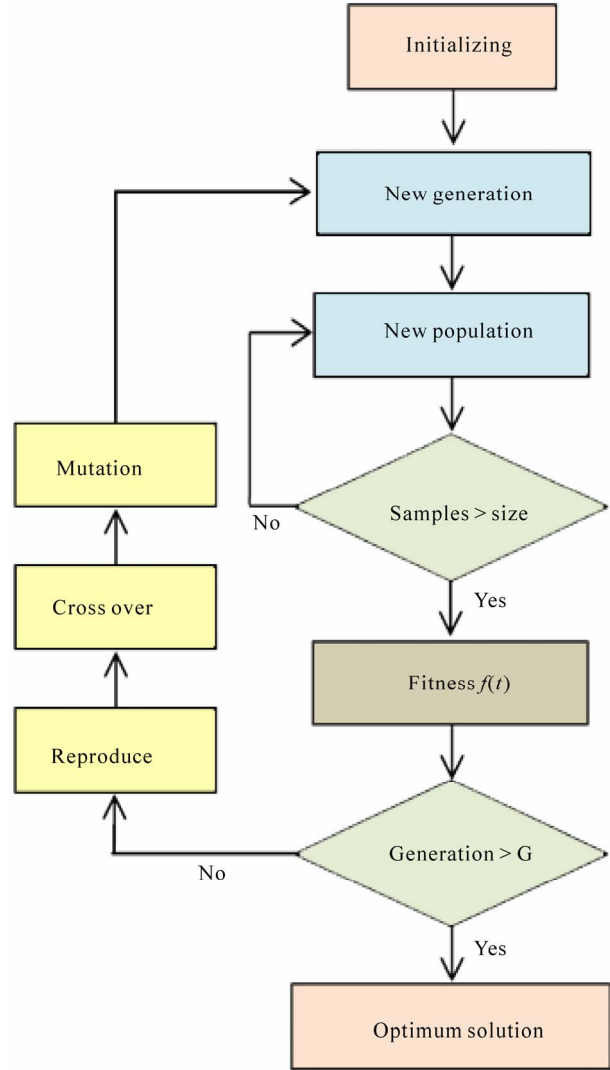

**Figure 2. The optimization flowchart of GA technique.**

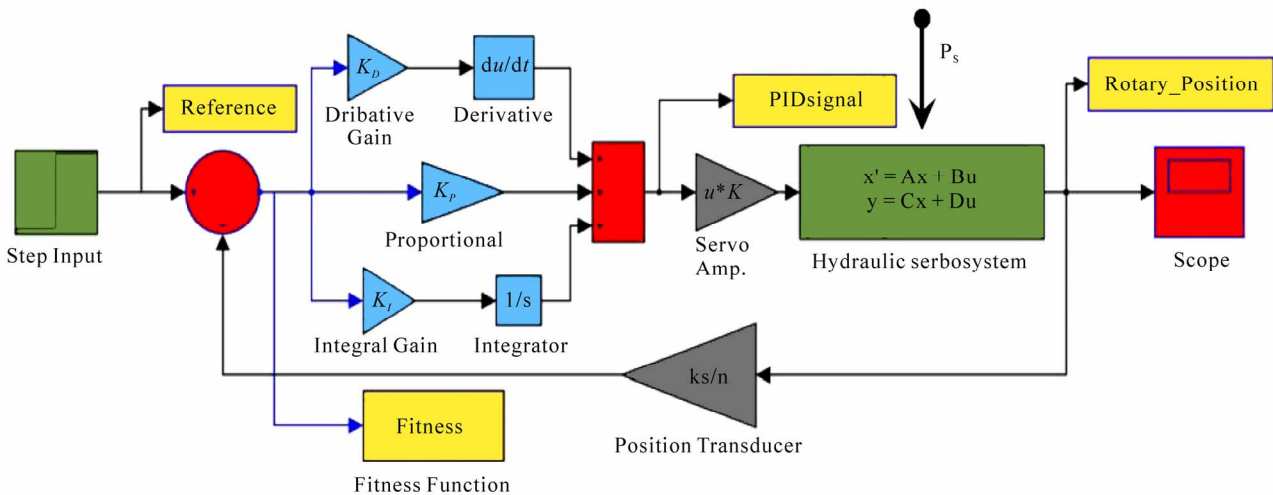

**Figure 3. Block diagram of electrohydraulic servo motor to adjust PID parameters via GA online.**

**Table 1. Specification of the GA.**

Population Size	20
Crossover Rate	0.7
Mutation Rate	0.05
Chromosome Length	12
Precision of Variables	3
Generation Gap	1

method where,  $K_P = 1.2560$ ,  $K_I = 0.0062$  and  $K_D = 0.0275$ . A fitness evaluation function is needed to calculate the overall responses for each of the sets of PID values and from the responses generates a fitness value for each set of individuals expressed by:

$$f(t) = \int_0^t |e(t)| dt \quad (7)$$

Here the goal is to find a set of PID parameters that will give a minimum fitness value over the period  $[0, t]$ . When this cycle is completed, are produced new sets of PID values which ideally will be at the fitness level higher than the initial population of PID values. These new fitter sets of PID values are then passed to the fitness evaluation function again where the above-mentioned process is repeated. This way the process is cycled unceasingly until the best fitness is achieved. If the predefined termination criterion is not met, again a new population is obtained using various operators that would have better gene. The termination criterion may be formulated as the magnitude of difference between index value of previous generation and present generation becoming less than a prespecified value. The process continues till the termination criterion is fulfilled.

#### 4. Simulation of the System with GPID Controller

The closed loop control system was solved using numerical integration technique of Runge-Kutta method with sampling time of 0.001 s. The simulation method combines SIMULINK module and M functions where, the main program is realized in SIMULINK and the optimized PID controller is predicted using M function.

**Figure 4** shows the step responses of the rotary actuator obtained by using the optimized feedback. The optimal gains of PID controller are calculated to minimize the fitness function which was described in (7). Therefore some oscillations or offset in the transient response may be shown with the implemented PID control parameters. In order to reduce steady state error and oscillations in the transient response, the fitness function must be modified in order to include steady state error and the

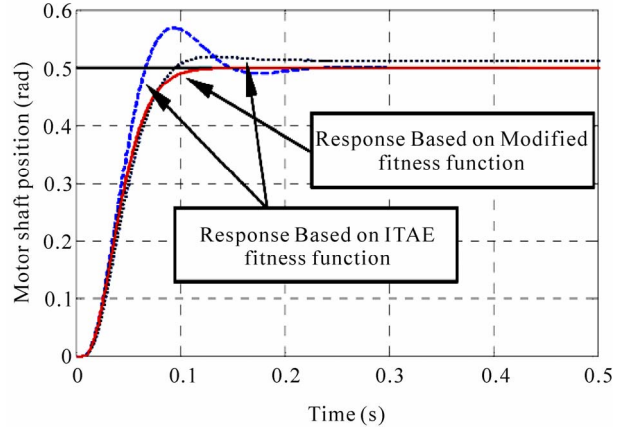

**Figure 4. The optimized motor shaft position of different fitness function.**

oscillations in the transient response. The modified fitness function is given by:

$$f(t) = \int_0^t |e(t)| dt + \alpha M_p + \beta e_{ss} \quad (8)$$

where  $\alpha$  and  $\beta$  are weighting factors equal to 1.5 and 5 respectively, imposed by the user to achieve desired response characteristics;  $M_p$  is the overshoot and  $e_{ss}$  is the steady-state error. The optimized PID parameters results at the assumed population of 20 are:  $K_P = 1.438$ ,  $K_I = 0.053$  and  $K_D = 0.537$ . At the same time, the nonlinear characteristics of the hydraulic motor and the hydraulic pump are also the reasons of steady state error and oscillations in the transient response. The settling time of the modified fitness function is significantly shorter than that achieved by the ITAE schemes.

The fitness distribution is computed by (8) and the plots in the  $K_P$ ,  $K_I$  and  $K_D$  ranges are shown in **Figures 5** and **6**, respectively. From the fitness distribution with respect to the number of generation plot, we can see that the near optimal values of feedback gains can obtain with in 10 generations, which corresponds to about 200 experiments. More than this number of experiments would be needed for manual tuning by an experienced technician. The optimal values of feedback gains are clearly defined in a given gain space. These figures also indicate that it would be very hard to determine optimal gains by manual tuning, because of the contrast behaviors of the controller parameters.

One of the important properties of any controller tuning method is its robustness to model errors. As a change in dynamics of the hydraulic servo systems, when the motor displacement is varied, the position responses also varied as shown in **Figure 7**. So that re-tuning of feedback gains must be carried out to obtain the desired control performance. However, the system remains stable in the presence of these changes.



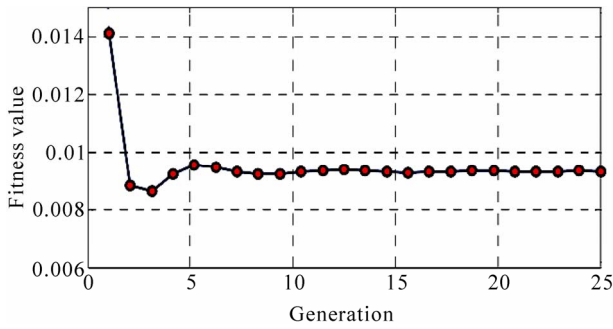

Figure 5. Fitness values with respect to the number of generation.

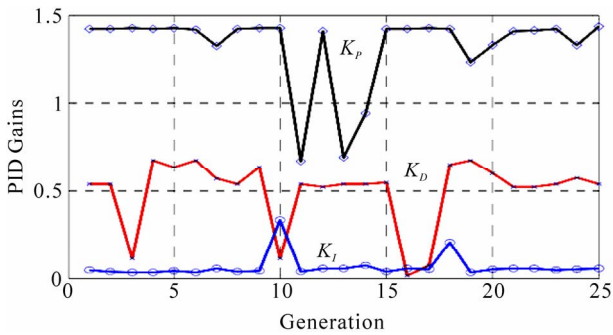

Figure 6. PID gains distribution with respect to the number of generation.

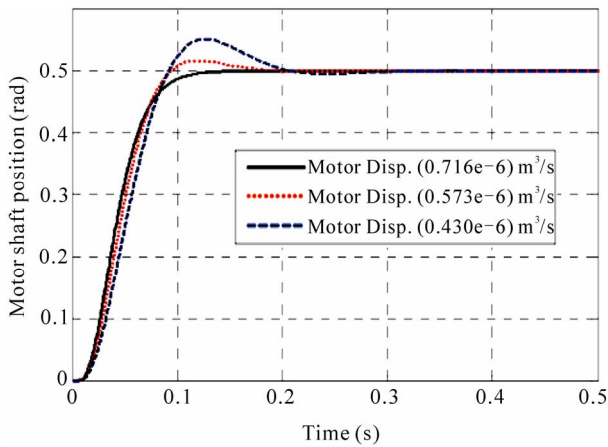

Figure 7. The optimized motor shaft position of different Motor displacement.

Figure 8(a) shows the ability of the system to track the a rectangle reference input with steady state error of 0.0027 rad., rise time of 0.115 s., and zero overshooting while, Figure 8(b) illustrates the controller signal achieved by the proposed design technique and the last parts shows that the servo valve flow rate kept under the saturation limit.

In Figures 9 and 10, a different reference signals have been used with this system and nearly similar results being achieved each time.

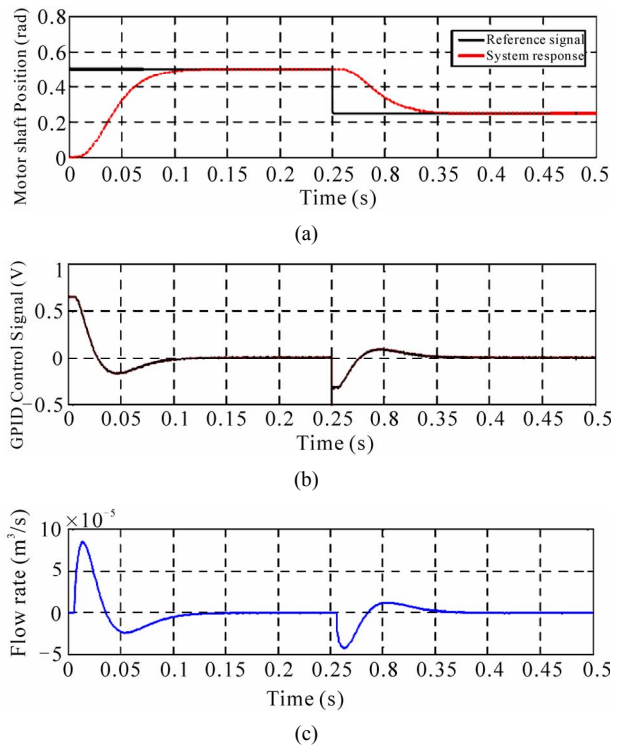

Figure 8. (a) The angular motor shaft position of square reference input; (b) GPID controller output; (c) Servo valve flow rate.

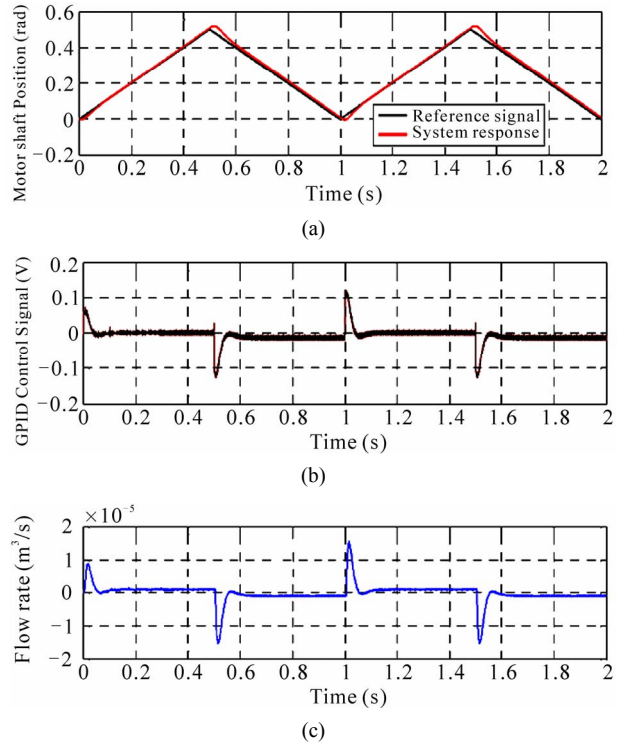
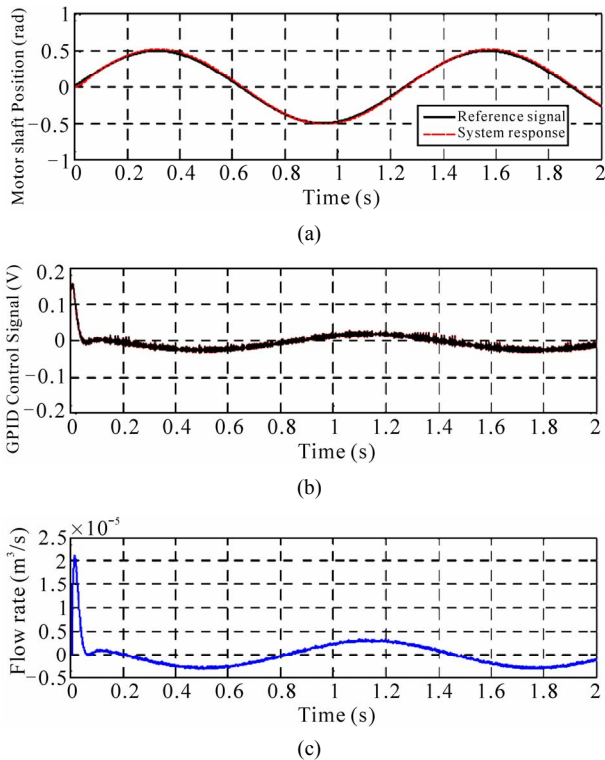

Figure 9. (a) The angular motor shaft position of saw tooth reference input; (b) GPID controller output; (c) Servo valve flow rate.



**Figure 10. (a) The angular motor shaft position of sin wave reference input; (b) GPID controller output; (c) Servovalve flow rate.**

## 5. Conclusions

This paper presents an optimization method of PID control parameters for the position control of nonlinear electrohydraulic servosystem by GA as a search technique with minimum information specific to the system such as the defined fitness function.

From the results, it is demonstrated that the optimized PID improve the performances of the hydraulic servosystem in order to achieve minimum settling time with no overshoot and nearly zero steady state error. The reciprocal of ITAE criterion is modified to be an appropriate fitness function for GA to evaluate the control performance of the given feedback gains. A disadvantage of the proposed method is the necessity of the definition of parameters for a performance index by the user, which impedes the procedure to be fully automatic. It seems to be easy to adapt the method presented here to tune other controller types, where some optimization is involved, such as LQR, LQG or pole placement controllers, when weighting parameters or weighting functions can be searched.

## 6. References

- [1] H. E. Merrit, "Hydraulic Control Systems," John Wiley & Sons Inc, New York, 1967.
- [2] J. Watton, "Fluid Power Systems," Prentice Hall, New Jersey, 1989.
- [3] J. E. Bobrow and K. Lum, "Adaptive, High Bandwidth Control of a Hydraulic Actuator," *Journal of Dynamic Systems, Measurement and Control, Transactions of the ASME*, Vol. 118, No. 4, 1996, pp. 714-720. [doi:10.1115/1.2802347](https://doi.org/10.1115/1.2802347)
- [4] T. L. Chern and Y. C. Wu, "Design of Integral Variable Structure Controller and Application to Electrohydraulic Velocity Servosystems," *IEEE Proceedings D*, Vol. 138, No. 5, 1991, pp. 439-444.
- [5] R.-F. Fung and R.-T. Yang, "Application of Variable Structure Controller in Position Control of a Nonlinear Electrohydraulic Servo System," *Computers & Structures*, Vol. 66, No. 4, 1998, pp. 365-372. [doi:10.1016/S0045-7949\(97\)00084-9](https://doi.org/10.1016/S0045-7949(97)00084-9)
- [6] G. Vossoughi and M. Donath, "Dynamic Feedback Linearization for Electrohydraulic Actuated Control Systems," *Journal of Dynamic Systems, Measurement and Control, Transactions of the ASME*, Vol. 117, No. 3, 1995, pp. 468-477. [doi:10.1115/1.2801102](https://doi.org/10.1115/1.2801102)
- [7] A. A. Aly, "Modeling and Control of an Electro-Hydraulic Servo Motor Applying Velocity Feedback Control Strategy," *International Mechanical Engineering Conference, IMEC2004*, Kuwait, 2004.
- [8] A. H. Jones and M. L. Tatnall, "Online Frequency Domain Identification for Genetic Tuning of PI Controllers," *Proceedings of ICSE*, Coventry University, Coventry, 1994.
- [9] "Moog 761 Series Servovalves," Moog Controls Inc., East Aurora.
- [10] W. Wang, J. T. Zhang and T. Y. A. Chai, "Survey of Advanced PID Parameter Tuning Methods," *Acta Automatica*, Vol. 26, No. 3, 2000, pp. 347-355.
- [11] M. H. Moradi, "New Techniques for PID Controller Design," *IEEE Conference on Control Applications*, Vol. 2, 2003, pp. 903-908.
- [12] A. A. Aly, "A Non Linear Optimal PID Control of a Hydraulic Crane," *Journal of Engineering Science*, Vol. 33, No. 1, 2007, pp. 199-209.
- [13] K. K. Tan, S. N. Huang and T. H. Lee, "Development of a GPC-based PID Controller for Unstable Systems with Dead Time," *ISA Transactions*, Vol. 39, 2000, pp. 57-70. [doi:10.1016/S0019-0578\(99\)00036-1](https://doi.org/10.1016/S0019-0578(99)00036-1)
- [14] P. Cominos and N. Munro, "PID Controllers: Recent Tuning Methods and Design to Specification," *IEE Proceedings Control Theory & Applications*, Vol. 149, No. 1, January 2002.
- [15] J. G. Ziegler and N. B. Nichols, "Optimum Settings for Automatic Controllers," *Transactions of the ASME*, Vol. 64, 1942, pp. 759-768.
- [16] C. Coon, "Theoretical Consideration of Retarded Control," *Transactions of the ASME*, Vol. 75, 1952, pp. 827-834.
- [17] L. Hao, C. L. Ma and F. Li, "Study of Adaptive PID Con-

troller Based on Single Neuron and Genetic Optimization,” *The 8<sup>th</sup> International Conference on Electronic Measurement and Instruments ICEMI*, Vol. 1, 2007, pp. 240-243.

- [18] J. R. Koza, F. H. Bennett, A. David and K. Martin, “A Genetic Programming III: Darwinian Invention and Problem Solving,” Morgan Kaufmann, San Francisco, 1999.
- [19] J. R. Koza, M. A. Keane, M. J. Streeter, W. Mydlowec, J.

Yu and G. Lanza, “Genetic Programming IV. Routine Human-Competitive Machine Intelligence,” Kluwer Academic Publishers, Dordrecht, 2003.

- [20] C. R. Reeves, “Using Genetic Algorithms with Small Populations,” *Proceedings of the 5th International Conference on Genetic Algorithms*, 1993.
- [21] D. E. Goldberg, “Genetic Algorithms in Search, Optimization and Machine Learning,” Addison-Wesley, New York, 1989.

## Appendix-A System Model and Parameters

The electrohydraulic valve consists of a first stage nozzle-flapper valve, and a second-stage 4-way spool valve. The valve drive amplifier has a gain of 100 mA/V. The model is derived on the assumption that an initially loaded rotary motor is controlled by the electrohydraulic servovalve. The steady-state valve model can be represented by the following relation, [4,5].

$$Q = K_x V_x \operatorname{sgn} \left[ 1 - \left( \operatorname{sgn} V_x \right) \frac{P_L}{P_s} \right] \sqrt{\left| 1 - \left( \operatorname{sgn} V_x \right) \frac{P_L}{P_s} \right|} \quad (\text{A-1})$$

The dynamic performance of the servovalve is described by a first-order time lag and is given by:

$$\tau \frac{dQ}{dt} + Q = K_x V_x \quad (\text{A-2})$$

Equations (A-1, A-2) are combined to yield a dynamic valve model as

$$\tau \frac{dQ}{dt} + Q = K_x V_x \operatorname{sgn} \left[ 1 - \left( \operatorname{sgn} V_x \right) \frac{P_L}{P_s} \right] \sqrt{\left| 1 - \left( \operatorname{sgn} V_x \right) \frac{P_L}{P_s} \right|} \quad (\text{A-3})$$

where  $v_x$  is the valve drive voltage,  $k_x = -1.36 \times 10^{-4} \text{ m}^3/\text{s/v}$ . is the valve flow gain, and  $\tau = 2.3 \times 10^{-3} \text{ s}$  is the valve time constant.

The hydraulic motor is modeled by considering the rotary motor arrangement shown in **Figure 1**, as well as by taking into account oil compressibility and leakage across the motor. Using the principal conservation of mass yields:

$$Q = V_m \frac{d\theta}{dt} + \frac{V_c}{4K_h} \frac{dP_L}{dt} + L_e P_L \quad (\text{A-4})$$

The equation of motion of the load can be given by:

$$P_L V_m = J \frac{d^2\theta}{dt^2} + B \frac{d\theta}{dt} + T_c \operatorname{sgn} \dot{\theta} \quad (\text{A-5})$$

where  $v_m = 0.716 \times 10^{-6} \text{ m}^3/\text{rad}$  is the motor displacement,  $v_c = 20.5 \times 10^{-6} \text{ m}^3$  is the volume of oil in motor

and hoses,  $k_h = 1.4 \times 10^9 \text{ N/m}^2$  is the hydraulic bulk modulus,  $L_e = 2.8 \times 10^{-11} \text{ m}^5/\text{Ns}$  is the effective leakage coefficient,  $J = 3.4 \times 10^{-3} \text{ Nms}^2/\text{rad}$  is the inertia of rotating Parts,  $B = 2.95 \times 10^{-3} \text{ Nms/rad}$  is the viscous damping coefficient,  $T_f = 0.225 \text{ N.M}$  is the magnitude of coulomb-friction, and the sign change function is defined by:

$$\operatorname{sgn} \dot{\theta} = \begin{cases} +1 & \text{for } \dot{\theta} > 1 \\ -1 & \text{for } \dot{\theta} < 1 \end{cases} \quad (\text{A-6})$$

The transport lag function is given by:

$$H(s) = e^{-0.06s} \quad (\text{A-7})$$

The system rotary position transducer constant,  $K_s = 3.44 \text{ v/rad}$  equipped with a 7.5 gear ratio.

## Nomenclature

$B$	Viscous damping coefficient, N·m·s/rad
$K_a$	Operational amplifier gain
$K_h$	Bulk modulus of fluid, N/m <sup>2</sup>
$K_x$	Valve flow gain at $P_L = 0$ . m <sup>3</sup> /s/V
$K_s$	Position transducer constant, V/rad/s
$K_\theta$	Position feedback gain
$J$	Load inertia, N·m·s <sup>2</sup> /rad
$L_e$	Equivalent leakage coefficient, m <sup>5</sup> /N·s
$n$	Reduction gear ratio
$P_1, P_2$	Pressures at actuator ports, N/m <sup>2</sup>
$P_L$	Load pressure, N/m <sup>2</sup>
$Q_1, Q_2$	Inlet and outlet flow of the actuator, m <sup>3</sup> /s
$Q$	Mean flow rate, m <sup>3</sup> /s
$T_c$	Coulomb -friction, N·m
$V_c$	Volume of oil in motor and hoses, m <sup>3</sup>
$V_i$	Input voltage to the system, V
$V_m$	Motor displacement, m <sup>3</sup> /rad
$V_x$	Valve drive voltage, V
$\tau$	Valve time constant, s
$\theta$	Shaft position, rad
$\dot{\theta}$	Angular frequency, rad/s