

A New Voltage-Mode Universal Biquadratic Filter Using Single UVC

Kanhaiya Lal Pushkar¹, Kavya Gupta², Pinky Vivek³

¹Department of Electronics and Communication Engineering, Maharaja Agrasen Institute of Technology, Rohini, New Delhi, India

²Electronics and Communication Engineering Cell, Radiance EdutechTM, DDA Market, Paschim Vihar, Delhi, India

³Department of Electronics and Communication Engineering, Al-Falah University, Faridabad, India

Email: klpushkar17@gmail.com, kavyagpt17@gmail.com, pinky.vivek18@gmail.com

How to cite this paper: Pushkar, K.L., Gupta, K. and Vivek, P. (2017) A New Voltage-Mode Universal Biquadratic Filter Using Single UVC. *Circuits and Systems*, 8, 275-284.

<https://doi.org/10.4236/cs.2017.812020>

Received: November 8, 2017

Accepted: December 24, 2017

Published: December 27, 2017

Copyright © 2017 by authors and Scientific Research Publishing Inc.

This work is licensed under the Creative Commons Attribution International License (CC BY 4.0).

<http://creativecommons.org/licenses/by/4.0/>



Open Access

Abstract

The paper presents a new universal biquadratic filter using single universal voltage conveyor (UVC), two resistors and two capacitors. The offered structure has three inputs and one output and can realise all the five basic biquadratic filters: high-pass (HP), low-pass (LP), band-reject (BR), band-pass (BP) and all-pass (AP) from the same circuit topology. The proposed universal filter also provides following advantageous features, not available simultaneously in any UVC based universal biquadratic filter so far: (i) low active and passive sensitivities, (ii) independent control of natural frequency (ω_0) and bandwidth (BW) and (iii) no requirement of any component matching condition and inversion of input signal(s) (as needed in most of the earlier reported structures). The workability of proposed structure has been presented by SPICE (Version 16.5) simulation using 0.18 μm TSMC technology.

Keywords

Analog Circuit, Universal Voltage Conveyor, Voltage-Mode, Filters

1. Introduction

Interest in the design of multi-input single-output (MISO) or single-input multi-output (SIMO), current-mode (CM) or voltage-mode (VM) universal filter configurations have been emerging, due to their flexibility and versatility for practical applications [1]. In literature [2]-[7], filter structures using different active building blocks/devices (such as current differencing transconductance amplifier, current differencing buffered amplifier, modified current feedback operational amplifier and current feedback operational amplifier) have been presented over the past few years. In ref [8], Herenscar, Koton and Vrba have presented multi-

function filter structures, employing three UVCs could realize only three basic filters (*i.e.* LP, HP, and BP). In ref [9], Minarcik and Vrba have proposed three multi-function filter structures: i) realize three basic filters *i.e.* LP, HP, and BP using three UVCs ii) realize four basic filters *i.e.* LP, HP, BP and, AP using two UVCs which can iii) four basic filters *i.e.* LP, HP, BP and, AP, employing single UVC. Filter structures presented in references [8] [9] are unable to realize all the basic bi-quadratic filter functions from single topology (*i.e.* LP, HP, BP, BR and AP).

In ref. [10], Pushkar and Gupta presented another universal filter in which all basic filter functions (LP, HP, BP, BR and AP) are realised however, the normalized gain of bandpass filter is approximately half which limits its applications, component matching and scaling of input signal is also required. Therefore, the purpose of this paper is to propose a new universal MISO-type VM biquad with three inputs and one output, which can realize all basic filter functions, namely: LP, HP, BP, BR and AP with no component matching and scaling of input signal is required. Comparison with other previously known MISO-type biquads using different active building blocks is shown in **Table 2**. The proposed filter is verified by SPICE (Version 16.5) simulations using 0.18 μm TSMC technology.

2. Proposed Filter Configuration

The Universal Voltage Conveyor is a 6-port active element with one voltage input x , two difference current inputs (y^+ , y^-), two mutually inverse voltage outputs (z^+ , z^-), and one auxiliary port w . **Figure 1(a)** and **Figure 1(b)** show the

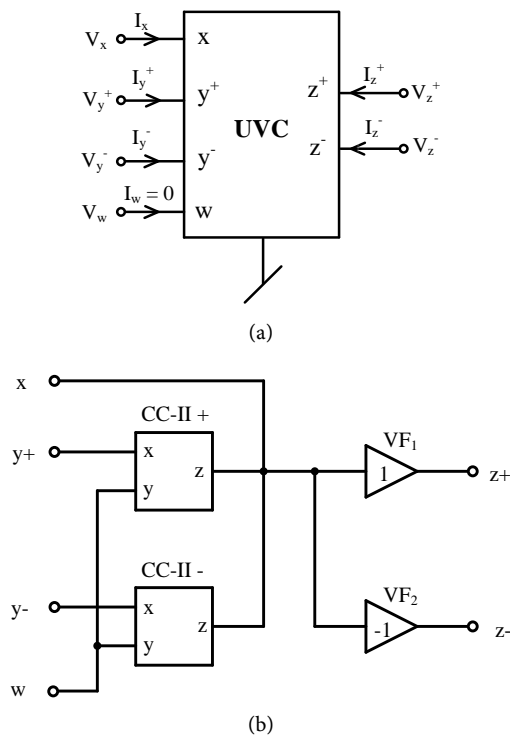

Figure 1. (a) Schematic symbol of UVC. (b) Ideal circuit model of UVC [11].

schematic symbol and ideal circuit model of UVC respectively. The relationship between port currents and voltages of a six port UVC is given in the following matrix.

$$\begin{pmatrix} I_x \\ I_w \\ V_{y^+} \\ V_{y^-} \\ V_{z^+} \\ V_{z^-} \end{pmatrix} = \begin{pmatrix} 0 & 0 & 1 & -1 & 0 & 0 \\ 0 & 0 & 0 & 0 & 0 & 0 \\ 0 & 1 & 0 & 0 & 0 & 0 \\ 0 & 1 & 0 & 0 & 0 & 0 \\ 1 & 0 & 0 & 0 & 0 & 0 \\ -1 & 0 & 0 & 0 & 0 & 0 \end{pmatrix} \begin{pmatrix} V_x \\ V_w \\ I_{y^+} \\ I_{y^-} \\ I_{z^+} \\ I_{z^-} \end{pmatrix} \quad (1)$$

A routine circuit analysis (assuming ideal UVC) of **Figure 2** yields the following expression for the voltage transfer function of the biquad:

$$V_o = \frac{V_2(s^2) - V_1\left(\frac{s}{C_2R_2}\right) + V_3\left(\frac{1}{C_1C_2R_1R_2}\right)}{s^2 + \frac{s}{C_2R_2} + \frac{1}{R_1R_2C_1C_2}} \quad (2)$$

From Equation (2), second order filter functions (LP, HP, BP, BR and AP) can be realized.

- 1) If $V_3 = V_{in}$, $V_2 = V_1 = 0$ (grounded), a low pass filter can be realized.

$$T(s)|_{LP} = \frac{1}{C_1C_2R_1R_2 D(s)}$$

- 2) If $V_2 = V_{in}$ and $V_3 = V_1 = 0$ (grounded), a high pass filter can be realized.

$$T(s)|_{HP} = \frac{s^2}{D(s)}$$

- 3) If $V_1 = V_{in}$ and $V_2 = V_3 = 0$ (grounded), a band pass filter can be realized.

$$T(s)|_{BP} = \frac{-s}{C_2R_2 D(s)}$$

- 4) If $V_3 = V_2 = V_{in}$ and $V_1 = 0$, a band reject filter can be realized.

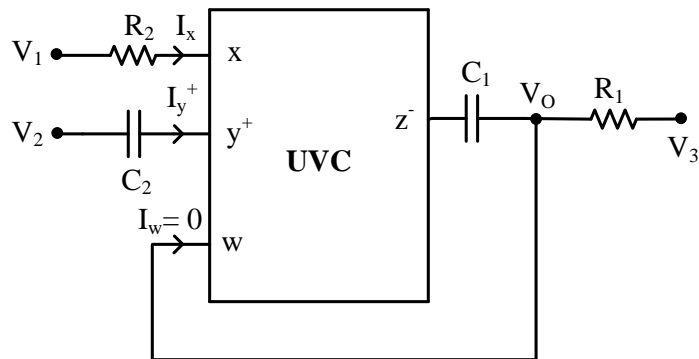

Figure 2. The proposed MISO-type voltage-mode universal biquad.

$$T(s)|_{BR} = \frac{s^2 + \frac{1}{R_1 R_2 C_1 C_2}}{D(s)}$$

5) If $V_1 = V_2 = V_3 = V_{in}$, a all pass filter can be realized.

$$T(s)|_{AP} = \frac{s^2 - \frac{s}{C_2 R_2} + \frac{1}{R_1 R_2 C_1 C_2}}{D(s)}$$

where: $D(s) = s^2 + \frac{s}{C_2 R_2} + \frac{1}{R_1 R_2 C_1 C_2}$

The expressions for quality factor (Q_0), bandwidth (BW) and natural frequency (ω_0), respectively are given by:

$$Q_0 = \sqrt{\frac{R_2 C_2}{R_1 C_1}}, \quad BW = \frac{1}{C_2 R_2}, \quad \omega_0 = \sqrt{\frac{1}{R_1 R_2 C_1 C_2}} \tag{3}$$

From (3), it can be observed that after adjusting BW by R_2 , ω_0 can independently be controlled through R_1 . Furthermore, it is seen that no inversion of input signal(s) and no component matching condition is required while realizing any of the five filter functions.

In the ideal case, the various sensitivities of ω_0 and BW with respect to R_1 , R_2 , C_1 , and C_2 are found to be:

$$S_{C_1}^{\omega_0} = S_{C_2}^{\omega_0} = S_{R_1}^{\omega_0} = S_{R_2}^{\omega_0} = -\frac{1}{2} \tag{4}$$

$$S_{C_1}^{BW} = 0, \quad S_{C_2}^{BW} = -1, \quad S_{R_1}^{BW} = 0, \quad S_{R_2}^{BW} = -1 \tag{5}$$

3. Non-Ideal Analysis and Sensitivity Performance

Taking into account the non-idealities of UVC, the relationship between the port voltages and currents is shown by the hybrid matrix:

$$\begin{pmatrix} I_x \\ I_w \\ V_{y^+} \\ V_{y^-} \\ V_{z^+} \\ V_{z^-} \end{pmatrix} = \begin{pmatrix} 0 & 0 & \alpha_1 & -\alpha_2 & 0 & 0 \\ 0 & 0 & 0 & 0 & 0 & 0 \\ 0 & \delta_1 & 0 & 0 & 0 & 0 \\ 0 & \delta_2 & 0 & 0 & 0 & 0 \\ \gamma_1 & 0 & 0 & 0 & 0 & 0 \\ -\gamma_2 & 0 & 0 & 0 & 0 & 0 \end{pmatrix} \begin{pmatrix} V_x \\ V_w \\ I_{y^+} \\ I_{y^-} \\ I_{z^+} \\ I_{z^-} \end{pmatrix} \tag{6}$$

where $\alpha_j = 1 - \varepsilon_{ij}$ and $\delta_j = 1 - \varepsilon_{v1j}$, $\gamma_j = 1 - \varepsilon_{v2j}$ for $j = 1, 2$. Here ε_{ij} ($|\varepsilon_{ij}| \ll 1$) and ε_{v1j} , ε_{v2j} ($|\varepsilon_{v1j}|, |\varepsilon_{v2j}| \ll 1$) represent the current and voltage tracking errors of the UVC respectively. The parasitic present on the low impedance ports (y^+ , y^- , z^+ , z^-) are quite low as compared to the resistances on the other ports (w and x) [12]. After considering the non-idealities of the UVC, given by the hybrid matrix of Equation (6), transfer function presented in Equation (2) can be modified as follows:

$$V_0 = \frac{\alpha_1 \gamma_2 V_2 (s^2 C_1 C_2) - \gamma_2 V_1 \left(s \frac{C_1}{R_2} \right) + \frac{V_3}{R_1} \left(s C_x + \frac{1}{R_2} + \frac{1}{R_x} \right)}{s^2 (\alpha_1 \delta_1 \gamma_2 C_1 C_2 + C_1 C_x + C_w C_x) + s \left((C_1 + C_w) \left(\frac{1}{R_2} + \frac{1}{R_x} \right) + C_x \left(\frac{1}{R_1} + \frac{1}{R_w} \right) \right) + \left(\frac{1}{R_2} + \frac{1}{R_x} \right) \left(\frac{1}{R_1} + \frac{1}{R_w} \right)} \quad (7)$$

$$\omega_0 = \sqrt{\frac{\left(\frac{1}{R_2} + \frac{1}{R_x} \right) \left(\frac{1}{R_1} + \frac{1}{R_w} \right)}{C_1 C_x + C_w C_x + \alpha_1 \delta_1 \gamma_2 C_1 C_2}} \quad (8)$$

$$BW = \frac{(C_1 + C_w) \left(\frac{1}{R_2} + \frac{1}{R_x} \right) + C_x \left(\frac{1}{R_1} + \frac{1}{R_w} \right)}{C_1 C_x + C_w C_x + \alpha_1 \delta_1 \gamma_2 C_1 C_2} \quad (9)$$

The sensitivity is an important performance criterion of any circuit structure. The sensitivity of Natural Frequency (ω_0) with respect to circuit parameters, say A is given as:

$$S_A^{\omega_0} = \frac{A}{\omega_0} \frac{\partial \omega_0}{\partial A} \quad (10)$$

Using above definition, the various active and passive sensitivities of Natural Frequency (ω_0) and Bandwidth (BW), for the biquadratic filter, with respect to $C_1, C_2, C_x, C_w, R_1, R_2, R_x, R_w, \alpha_1, \delta_1$ and γ_2 are found to be:

$$S_{C_1}^{\omega_0} = -\frac{1}{2} \left(\frac{C_1 C_x + \alpha_1 \delta_1 \gamma_2 C_1 C_2}{C_1 C_x + C_w C_x + \alpha_1 \delta_1 \gamma_2 C_1 C_2} \right), S_{C_x}^{\omega_0} = -\frac{1}{2} \left(\frac{C_1 C_x + C_w C_x}{C_1 C_x + C_w C_x + \alpha_1 \delta_1 \gamma_2 C_1 C_2} \right) \quad (11)$$

$$S_{C_2}^{\omega_0} = -\frac{1}{2} \left(\frac{\alpha_1 \delta_1 \gamma_2 C_1 C_2}{C_1 C_x + C_w C_x + \alpha_1 \delta_1 \gamma_2 C_1 C_2} \right) = S_{\alpha_1}^{\omega_0} = S_{\delta_1}^{\omega_0} = S_{\gamma_2}^{\omega_0} \quad (12)$$

$$S_{C_w}^{\omega_0} = -\frac{1}{2} \left(\frac{C_w C_x}{C_1 C_x + C_w C_x + \alpha_1 \delta_1 \gamma_2 C_1 C_2} \right), S_{R_2}^{\omega_0} = -\frac{1}{2} \left(\frac{1}{1 + \frac{1}{R_x}} \right), S_{R_x}^{\omega_0} = -\frac{1}{2} \left(\frac{1}{1 + \frac{1}{R_x}} \right) \quad (13)$$

$$S_{R_w}^{\omega_0} = -\frac{1}{2} \left(\frac{1}{1 + \frac{1}{R_w}} \right), S_{R_1}^{\omega_0} = -\frac{1}{2} \left(\frac{1}{1 + \frac{1}{R_w}} \right) \quad (14)$$

$$S_{C_1}^{BW} = -\frac{C_1 \left(C_x^2 \left(\frac{1}{R_1} + \frac{1}{R_w} \right) + \alpha_1 \delta_1 \gamma_2 C_2 \left(C_1 \left(\frac{1}{R_2} + \frac{1}{R_x} \right) + C_x \left(\frac{1}{R_1} + \frac{1}{R_w} \right) \right) \right)}{\left((C_1 + C_w) \left(\frac{1}{R_2} + \frac{1}{R_x} \right) + C_x \left(\frac{1}{R_1} + \frac{1}{R_w} \right) \right) (C_1 C_x + C_w C_x + \alpha_1 \delta_1 \gamma_2 C_1 C_2)} \quad (15)$$

$$S_{C_w}^{BW} = -\frac{C_w \left(C_x^2 \left(\frac{1}{R_1} + \frac{1}{R_w} \right) + \alpha_1 \delta_1 \gamma_2 C_2 C_1 \left(\frac{1}{R_2} + \frac{1}{R_x} \right) \right)}{\left((C_1 + C_w) \left(\frac{1}{R_2} + \frac{1}{R_x} \right) + C_x \left(\frac{1}{R_1} + \frac{1}{R_w} \right) \right) (C_1 C_x + C_w C_x + \alpha_1 \delta_1 \gamma_2 C_1 C_2)} \quad (16)$$

$$S_{C_x}^{BW} = -\frac{C_x \left((C_1 + C_w)^2 \left(\frac{1}{R_2} + \frac{1}{R_x} \right) + \alpha_1 \delta_1 \gamma_2 C_2 C_1 \left(\frac{1}{R_1} + \frac{1}{R_w} \right) \right)}{\left((C_1 + C_w) \left(\frac{1}{R_2} + \frac{1}{R_x} \right) + C_x \left(\frac{1}{R_1} + \frac{1}{R_w} \right) \right) (C_1 C_x + C_w C_x + \alpha_1 \delta_1 \gamma_2 C_1 C_2)} \quad (17)$$

$$S_{C_2}^{BW} = -\frac{\alpha_1 \delta_1 \gamma_2 C_1 C_2}{C_1 C_x + C_w C_x + \alpha_1 \delta_1 \gamma_2 C_1 C_2} = S_{\alpha_1}^{BW} = S_{\delta_1}^{BW} = S_{\gamma_2}^{BW} \quad (18)$$

$$S_{R_1}^{BW} = \frac{-\frac{C_x}{R_1}}{(C_1 + C_w) \left(\frac{1}{R_2} + \frac{1}{R_x} \right) + C_x \left(\frac{1}{R_1} + \frac{1}{R_w} \right)}, \quad (19)$$

$$S_{R_w}^{BW} = \frac{-\frac{C_x}{R_w}}{(C_1 + C_w) \left(\frac{1}{R_2} + \frac{1}{R_x} \right) + C_x \left(\frac{1}{R_1} + \frac{1}{R_w} \right)}$$

$$S_{R_2}^{BW} = \frac{-\frac{(C_1 + C_w)}{R_2}}{(C_1 + C_w) \left(\frac{1}{R_2} + \frac{1}{R_x} \right) + C_x \left(\frac{1}{R_1} + \frac{1}{R_w} \right)}, \quad (20)$$

$$S_{R_x}^{BW} = \frac{-\frac{(C_1 + C_w)}{R_x}}{(C_1 + C_w) \left(\frac{1}{R_2} + \frac{1}{R_x} \right) + C_x \left(\frac{1}{R_1} + \frac{1}{R_w} \right)}$$

Considering the typical values of various parasitic [13] e.g. $C_x = 17.41$ pF, $R_x = 378.73$ k Ω , $C_w = 4.19$ pF, $R_w = 88.19$ M Ω , $\alpha_1 = \delta_1 = \gamma_2 = 1$ along with $C_1 = C_2 = 10$ pF, $R_1 = R_2 = 100$ k Ω , the various sensitivities are found to be $S_{C_1}^{\omega_0} = -0.253$, $S_{C_2}^{\omega_0} = S_{\alpha_1}^{\omega_0} = S_{\delta_1}^{\omega_0} = S_{\gamma_2}^{\omega_0} = -0.143$, $S_{C_x}^{\omega_0} = -0.355$, $S_{C_w}^{\omega_0} = -0.104$, $S_{R_w}^{\omega_0} = -0.0056$, $S_{R_1}^{\omega_0} = -0.495$, $S_{R_2}^{\omega_0} = -0.395$, $S_{R_x}^{\omega_0} = -0.104$ and $S_{C_1}^{BW} = -0.5001$, $S_{C_2}^{BW} = S_{\alpha_1}^{BW} = S_{\delta_1}^{BW} = S_{\gamma_2}^{BW} = -0.2861$, $S_{C_x}^{BW} = -0.4981$, $S_{C_w}^{BW} = -0.1484$, $S_{R_w}^{BW} = -0.0053$, $S_{R_1}^{BW} = -0.5006$, $S_{R_2}^{BW} = -0.4125$, $S_{R_x}^{BW} = -0.1089$. It is clearly observed that none of the active and passive sensitivities are more than one half in magnitudes for the proposed VM biquad filter.

4. Simulation Results

To confirm the feasibility of the presented biquadratic filter, the circuit was simulated using SPICE. The voltage and current values selected for CMOS implementation of UVC are ± 1.9 V and 100 μ A, respectively. The passive elements were chosen as $C_1 = C_2 = 10$ pF, $R_1 = R_2 = 100$ k Ω . The natural frequency (ω_0) and BW of the proposed filter for the selected passive elements are 87.498 kHz and 151.266 kHz respectively. CMOS implementation of universal voltage conveyor is shown in **Figure 3** and the aspect ratios of MOSFETs used in **Figure 3** are given in **Table 1** [14]. CMOS UVC was implemented 0.18 μ m TSMC CMOS model parameters [15].

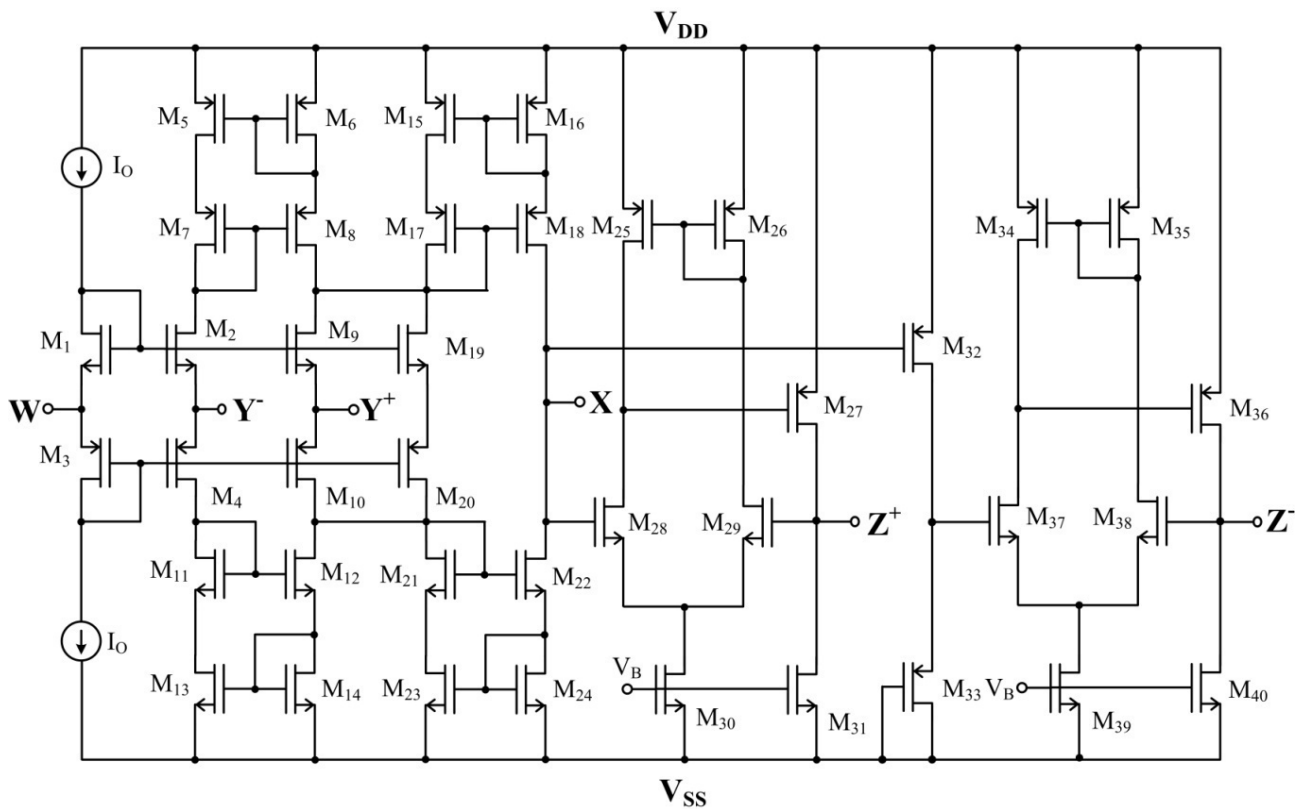

Figure 3. Implementation of CMOS structure of UVC, $V_{DD} = -V_{SS} = 1.9$ V, $I_o = 100$ μ A.

Table 1. The aspect ratios (W/L) of transistors used in **Figure 3**.

PMOS transistors	W (μ m)/L (μ m)
M5-M8, M10, M15-M18, M20	14.0/0.7
M3, M4	28/0.7
M25, M26, M34, M35	4.0/0.5
M27, M36	10.0/0.5
M32, M33	2.1/1.0
NMOS transistors M1, M2	W (μ m)/L (μ m)
M1, M2	14.0/0.7
M9, M11-M14, M19, M21-M24	28/0.7
M28, M29, M37, M38	0.8/0.5
M30, M31, M39, M40	10/0.5

A comparison with other previously known MISO-type biquads using different active building blocks has been shown in **Table 2**, the proposed structure gives all basic filter functions and free from any matching conditions. The SPICE simulated frequency response of the biquad is shown in **Figures 4-6** represent the magnitude and phase plot of APF, respectively. These plots are nearly similar to the standard second order filters: LPF, HPF, BPF, APF and BRF. Therefore, these responses confirm the validity of the proposed biquadratic filter.

Table 2. A comparison with other previously known MISO-type biquads using different active building blocks.

Reference	No. of active building blocks	External resistors used	Is realization free from matching condition(s)?	Number of standard filter realized
[2]	1	3	NO	5
[4]	1	4	NO	5
[5]	1	3	NO	5
[6]	1	2	NO	5
[7]	1	3	NO	5
[8]	3	5	YES	3 (LP, HP, BP)
	3	5	YES	3 (LP, HP, BP)
[9]	2	3	YES	4 (LP, HP, BP, AP)
	1	2	YES	4 (LP, HP, BP, AP)
[10]	1	2	NO	5
Proposed	1	2	YES	5

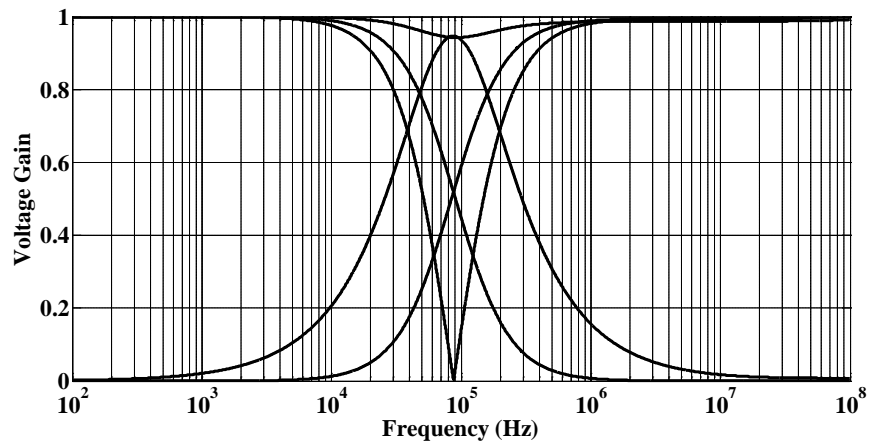

Figure 4. Frequency response of the proposed biquad filter.

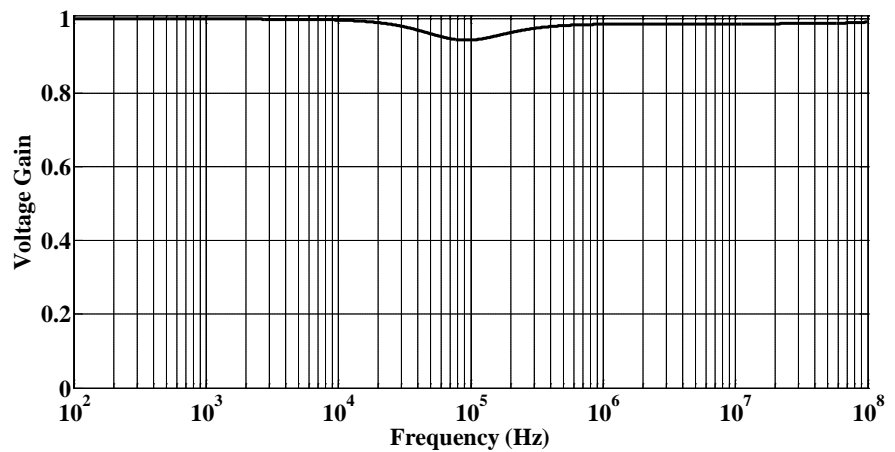

Figure 5. Frequency response of all-pass filter.

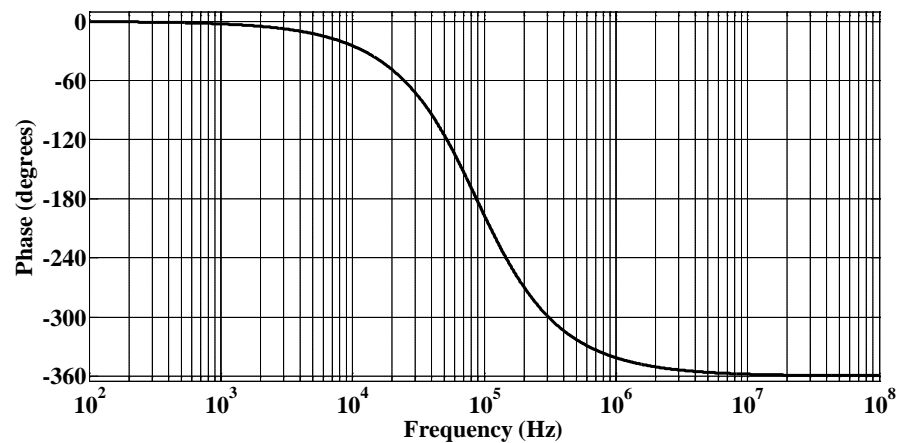

Figure 6. Phase response of all-pass filter.

5. Conclusions

A new second order voltage-mode MISO-type universal biquadratic filter using single UVC has been presented. The proposed filter offers following advantages: i) employment of single active component; ii) ability to realize all the basic second order filters without altering the circuit configuration; iii) low active and passive sensitivities; iv) free from component matching conditions; v) independent control of natural frequency and bandwidth. On the basis of above mentioned features of the proposed biquadratic filter, it can be used for various low voltage applications. The workability of the presented circuit configuration has been established by SPICE simulation using 0.18 μm TSMC CMOS technology.

References

- [1] Pushkar, K.L., Bhaskar, D.R. and Prasad, D. (2013) Voltage-Mode New Universal Biquad Filter Configuration Using a Single VDIBA. *Circuits, Systems, Signal, and Processing*, **33**, 275-285.
- [2] Prasad, D., Bhaskar, D.R. and Singh, A.K. (2009) Multi-Function Biquad Using Single Current Differencing Transconductance Amplifier. *Analog Integrated Circuits and Signal Processing*, **61**, 309-313. <https://doi.org/10.1007/s10470-009-9310-1>
- [3] Keskin, A.U. (2006) Multi-Function Biquad Using Single CDDBA. *Electrical Engineering*, **88**, 353-356. <https://doi.org/10.1007/s00202-004-0289-4>
- [4] Bashir, S.A. and Shah, N.A. (2012) Voltage Mode Universal Filter Using Current Differencing Buffered Amplifier as an Active Device. *Circuits and Systems*, **3**, 1-4. <https://doi.org/10.4236/cs.2012.33038>
- [5] Herencsar, N., Koton, J., Vrba, K. and Cicekoglu, O. (2009) Single UCC-N1B 0520 Device as a Modified CFOA and Its Application to Voltage- and Current-Mode Universal Filters. *Applied Electronics, Pilsen*, **9**, 127-130.
- [6] Shah, N.A., Rather, M.F. and Iqbal, S.Z. (2005) A Novel Voltage-Mode Universal Filter Using a Single CFA. *Active and Passive Electronic Devices*, **1**, 183-188.
- [7] Horng, J.W., Chang, C.K. and Chu, J.M. (2002) Voltage-Mode Universal Biquadratic Filter Using Single Current-Feedback Amplifier. *IEICE Transactions on Fundamentals*, **85**, 1970-1973.

- [8] Herencsar, N., Koton, J. and Vrba, K. (2011) KHN-Equivalent Voltage-Mode Filters Using Universal Voltage Conveyors. *AEU - International Journal of Electronics and Communications*, **65**, 154-160. <https://doi.org/10.1016/j.aeue.2010.02.005>
- [9] Minarcik, M. and Vrba, K. (2007) Continuous-Time Multifunctional Filters with Wide Bandwidth Using Universal Voltage Conveyors. *Proceedings of the Sixth International Conference on Networking*. <https://doi.org/10.1109/ICN.2007.32>
- [10] Pushkar, K.L. and Gupta, K. (2017) MISO-Type Voltage-Mode Universal Biquadratic Filter Using Single Universal Voltage Conveyor. *Circuits and Systems*, **8**, 227-236. <https://doi.org/10.4236/cs.2017.89015>
- [11] Minarcik, M. and Vrba, K. (2006) Low-Output and High-Input Impedance Frequency Filters Using Universal Voltage Conveyor for High-Speed Data Communication Systems. In *Proceedings of international conference on networking ICN 2006*, Mauritius, 155-158.
- [12] Herencsar, N., Koton, J. and Vrba, K. (2009) A New Electronically Tunable Voltage-Mode Active-C Phase Shifter Using UVC and OTA. *IEICE Electronics Express*, **6**, 1212-1218. <https://doi.org/10.1587/elex.6.1212>
- [13] Sponar, R. and Vrba, K. (2006) Measurements and Behavioral Modeling of Modern Conveyors. (*IJCSNS*) *International Journal of Computer Science and Network Security*, **6**, 57-65.
- [14] Herencsar, N., Koton, J., Vrba, K. and Minaei, S. (2011) Electronically Tunable MOSFET-C Voltage-Mode All Pass Filter Based on Universal Voltage Conveyor. (*ICCSN*) *Communication Software and Networks*, 442-445. <https://doi.org/10.1109/ICCSN.2011.6014931>
- [15] Minaei, S. and Yuce, E. (2010) Novel Voltage-Mode All-Pass Filter Based on Using DVCCs. *Circuits System and Signal Processing*, **29**, 391-402. <https://doi.org/10.1007/s00034-010-9150-3>